



## Main Features

- Intel Atom® processor quad core x7433RE, 1.5GHz
- Eight SIM cards + Four WWAN modules support
- Built-in u-blox-M9N GPS
- Built-in CAN FD
- 1 x External storage (compatible with 15mm disk)
- EN 50155, class OT4 conformity
- 3 x M.2 + 2 x mPCIe socket expansion
- Wide voltage input 24 VDC
- 1 x DB9 for 1 x Mic-in, 1 x Line-out, 1 x Line-In
- Three video outputs, VGA, HDMI, and DP

## Product Overview

nROK 6231, based on Intel® Core™ quad core processor x7433RE, is specifically comply with stringent EN50155 standard in rugged, fanless and compact mechanism. nROK 6231 provides complete communication capability between train and computer with build-in CAN FD interface. nROK 6231 features rich WLAN and WWAN wireless connectivity. With dual SIM cards per modem support, nROK 6231 allows eight SIM cards backup each other for a better connectivity quality or extra bandwidth by software. In addition, eight SIM cards and four WWAN modules architecture can increase the bandwidth for a faster data transmission speed. Equipped with intelligent power management, nROK 6231 can be waked on by ignition, RTC timer or SMS message remotely. By integrating the variety of I/O ports, 3 x M.2, 2 x mPCIe sockets expansibility, up to three screens via VGA, HDMI, and DP connections, nROK 6231 keeps the flexibility to meet the demand for different rolling stock applications, such as infotainment, dispatching system, cellular/wireless network connectivity, and video surveillance. The design of mini-PCIe slots x 2 can solve the potential request from the market when needed.

## Specifications

### CPU

- Intel Atom® processor x7433RE, 1.5GHz, 9W, 4-core

### Memory

- 1 x 262-pin DDR5 SO-DIMM socket support 4800MHz up to 16GB, default 8GB

### Video Output

- 1 x VGA up to 1920 x 1200 @60Hz
- 1 x HDMI 2.0 up to 4096 x 2160 @60Hz
- 1 x DP up to 4096 x 2160 @60Hz

### Storage

- 1 x 2.5" SATA 3.0 external SSD (compatible with 15mm drive)
- 1 x mSATA (occupy one mPCIe slot)

### Expansion

- 2 x M.2 3042/3050/3052 Key B socket (USB 2.0, USB 3.2 Gen 2) for LTE/5G NR module with 2 x external Nano-SIM
- 1 x Full size mini-PCIe socket (USB 2.0, SATA, PCIe 3.0) for mSATA (default), BIOS select (USB 2.0) for LTE with 2 x external Nano-SIM, BOM option (USB 2.0, PCIe 3.0) for WLAN
- 1 x M.2 2230 Key E (PCIe 3.0 x 1, USB 2.0), BOM optional mPCIe (PCIe 3.0 x 1, USB2.0) for Hailo module
- 1 x Full size mini-PCIe socket (USB 2.0, PCIe 3.0) for WiFi, BOM option M.2 3042/3050/3052 Key B socket (USB 2.0, USB 3.2 Gen 2) for LTE/5G NR module with 2 x external Nano-SIM

### GNSS and Onboard Sensor

- 1 x Default u-blox NEO-M9N GNSS for GPS/Glonass/QZSS/Galileo/Beidou
- G Sensor (3-axis, 10-bit resolution)

### LAN and Power over Ethernet

- 2-Port LAN, 10/100/1000/2500 Mbps i226-IT Ethernet Controller

### Security

- TPM 2.0: Infineon SLB9670VQ2.0

### I/O Interface-Front

- 12 x LED indicators (including 2 x programmable LED)
- 8 x Externally accessible SIM card sockets with cover
- 1 x 2.5" removable SSD tray (removable, 15mm)
- 1 x Reset button
- 1 x Power button
- 2 x USB 3.2 (Gen 2) type A
- 14 x SMA antenna

### I/O Interface-Rear

- 1 x Circle type DC input with ignition
  - 24 VDC (9~36 VDC), non-isolation
- 1 x M12 with two USB 2.0
- 2 x M12 X-coded LAN port, 10/100/1000/2500 Mbps
- 1 x DB9 (AUDIO), Female for 1 x Mic-in, 1 x Line-out, 1 x Line-In
- 1 x VGA, 1 x HDMI 2.0, 1 x DP

## Dimension Drawing

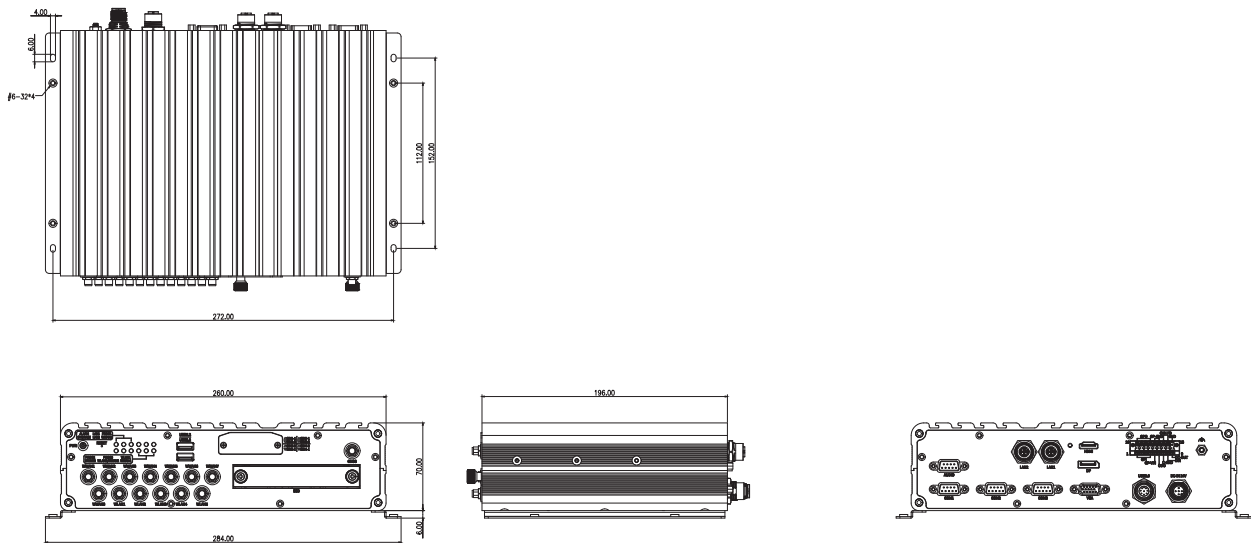

- 1 x DB9 (COM) full RS232 (isolation)
- 2 x DB9 for RS232/RS422/RS485 Full (all w/ isolation)
- 1 x 18-pin terminal block
  - 1 x CAN FD
  - 4 x DI with isolation
  - 4 x DO with isolation
  - 1 x GNSS Speed/Direction
  - Vin, GND for GPIO

### Power Management & Software Support

- Power input 24 VDC w/o isolation
- Selectable boot-up & shut-down voltage for low power protection by software
- Setting 8-level power on/off delay time by software
- Support S3/S4 suspend mode
- 10~255 seconds WDT support, setup by software
- SDK (Windows/Linux) including utility and sample code

### Operating System

- Windows 10, 11 (64-bit)
- Linux 4.x

### Dimensions

- 260mm (W) x 196mm (D) x 70mm (H) (10.24" x 7.79" x 2.75")

### Weight

- 2.8kg

### Environment

- Operating temperatures
  - EN 50155, class OT4 (-40~70°C), 85°C for 10 minutes (w/ industrial SSD) with air flow
- Storage temperatures: -40°C to 85°C
- Relative humidity: 10% to 90% (non-condensing)
- Vibration (random)
  - 2g@5~500 Hz (in operation, SSD)
- Vibration
  - IEC 60068-2-64, 2G for SSD
  - Operating: MIL-STD-810H, 514.8C Procedure 1, Category 4
  - Storage: MIL-STD-810H, 514.8E Procedure 1, Category 24

- Shock

- Operating: MIL-STD-810H, Method 516.8, Procedure I, functional shock=40g
- Non-operating: MIL-STD-810H, Method 516.8, Procedure V, crash hazard shock test=75g

### Standards/Certifications

- CE
- FCC Class A
- EN 50155: 2017
  - Ambient temperature EN 50155, Class OT4 (-40~70°C), 85°C for 10 minutes
  - Interruptions of voltage supply class S1
  - Supply change over class C1, C2
  - EMC EN 50121-3-2: 2016+A1: 2019
  - Environment EN 60068-2-1, EN 60068-2-2, EN 60068-2-30
  - Shock and vibration IEC 61373 Class B
  - Protective coating class PC1 (PC2, by request)
  - EN 45545-2:2013+A1:2015 (PCB)

## Ordering Information

### • nROK 6231-A (P/N: 10A00623100X0)

Intel Atom® processor x7433RE CPU, 8GB DDR5 SO-DIMM, DC input 24 VDC w/o isolation, 1 x VGA, 1 x HDMI, 1 x DP, 2 x LAN, 2 x selectable RS232/422/485 Full, 1 x RS232 Full, 8 x GPIO, 2 x USB 3.2, 2 x USB 2.0

### • nROK 6231-AI (P/N: 10A00623101X0)

Intel Atom® processor x7433RE CPU, 8GB DDR5 SO-DIMM, DC input 24 VDC w/ isolation, 1 x VGA, 1 x HDMI, 1 x DP, 2 x LAN, 2 x selectable RS232/422/485 Full, 1 x RS232 Full, 8 x GPIO, 2 x USB 3.2, 2 x USB 2.0

### • nROK 6231-FI (P/N: 10A00623102X0)

Intel Atom® processor x7433RE CPU, 8GB DDR5 SO-DIMM, DC input 110 VDC w/ isolation, 1 x VGA, 1 x HDMI, 1 x DP, 2 x LAN, 2 x selectable RS232/422/485 Full, 1 x RS232 Full, 8 x GPIO, 2 x USB 3.2, 2 x USB 2.0