



Main Features

- Compact and fanless design
- Built-in GPS receiver with optional dead reckoning function
- Variety of wireless communication options
- Built-in CAN bus 2.0B (BOM option SAE J1939)
- Smart power management with Ignition on/off delay via software control and low voltage protection
- Wide range DC input from 9~36V
- Certified by CE/FCC/E13 mark
- 5 x RS232 and 2 x RS485
- 3 x Audio-in and 3 x Audio-out switchable
- 3 x Video output (VGA + HDMI + LVDS)

Product Overview

VTC 1020-PA, a compact, rugged and entry-level vehicle computer with Intel Atom® x5-E3930 processor dual core 1.3GHz, is dedicated for public transportation application in harsh in-vehicle environment. Because of the compact design, it is especially for the vehicles with limited space to locate the computer system, but without compromising with its space to scarify its features.

VTC 1020-PA has 3 Audio-in and 3 Audio-out switchable that can be used as public announcement function, such as for driver, internal passengers and external passengers. Since it has 3 independant video output, it is flexible to provide different video content in PIS application. VTC 1020-PA has on board CAN 2.0B and optional OBD interface (SAE J1939) for vehicle diagnostics and driver behavior management. An advanced GPS receiver supports GPS/Gloness/QZSS/Galileo/Beidou and optional dead reckoning module is also available. VTC 1020-PA features WLAN and WWAN wireless data and voice connectivity. With external SIM socket, it allows user to access SIM card conveniently. 12VDC output can be provided for external display with easy power wire arrangement. VTC 1020-PA is very suitable for public transportation application, such as local bus, shuttle bus, tour bus and highway bus.

Specifications

CPU

- Intel Atom® x5-E3930 processor dual core 1.3GHz

Memory

- 1 x 204-pin DDR3L SO-DIMM socket support 1866MHz up to 8GB. Default 4GB

Expansion

- 1 x mini-PCIe socket (USB)
- 1 x mini-PCIe socket (PCIe + USB + mSATA)

Function

- 1 x u-blox NEO-M8N module (support GPS/Gloness/QZSS/Galileo/Beidou) or optional module with Dead Reckoning
- Built-in G-sensor
- Built-in TPM

I/O Interface-Front

- 1 x Power button
- 4 x LED indicators for Status (programmable), Storage, WLAN and WWAN
- 1 x System reset button
- 2 x Type A USB 3.0 compliant host, supporting system boot up
- 1 x DB-15 VGA

- 1 x HDMI
- 1 x external SIM card socket
- 1 x DB26 LVDS interface with 12VDC, USB 2.0 and power button
- 2 x Audio-in, 2 x Audio-out

I/O Interface-Rear

- 1 x 9~36VDC input with Ignition and 20W typical power consumption
- 1 x 12V/2A DC output, SMBus, power button
- 1 x RJ45 with LEDs for 10/100/1000Mbps Ethernet
- 1 x Audio-in, 1 x Audio-out
- 1 x DB15 COM port for 4 x RS232 Tx/Rx and 2 x RS485
- 1 x DB15 for multi port
 - 1 x CAN2.0 (BOM option SAE J1939)
 - 1 x RS232 Tx/Rx
 - 1 x odometer and direction for optional GPS DR
 - 5 x programmable DIO
- Input voltage (internal type): 5VDC TTL (default)
- Input voltage (source type): 3~24VDC
- Digital output (sink type): 5VDC TTL (default), max current: 20mA
- Digital output (source type): 3~24VDC
- 3 x Antenna hole for SMA-type antenna (WWAN/WLAN/GPS)

Dimension Drawing

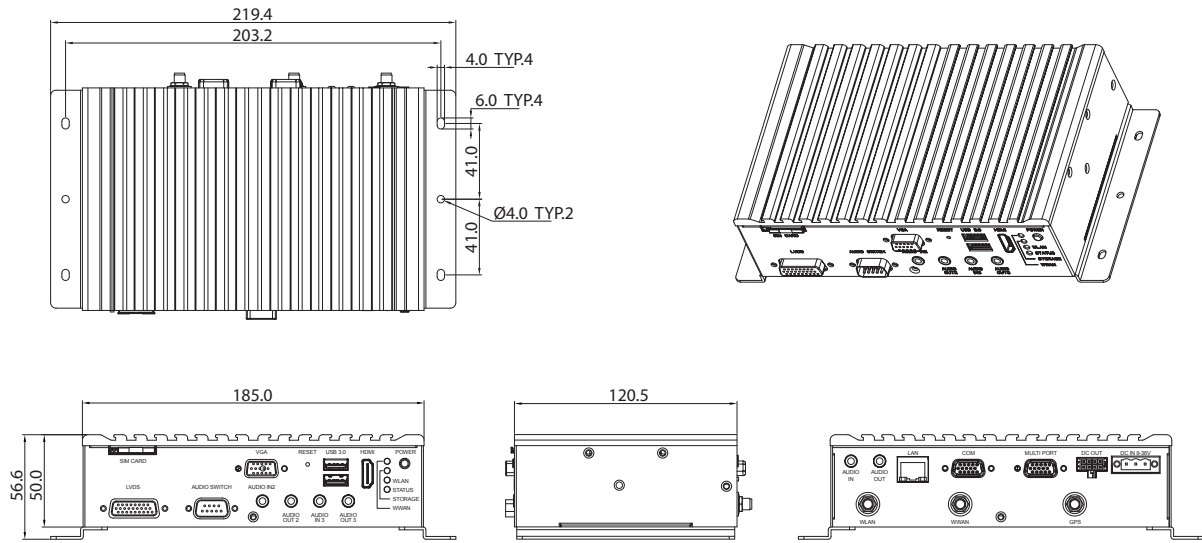

Expandable Storage

- 1 x 2.5" SSD SATA 3.0
- 1 x mSATA

Operating System

- Windows 10
- Linux YOCTO (by request)

Power Management

- Selectable boot-up & shut-down voltage for low power protection
- HW design ready for 8-level delay time on/off at user's self configuration
- Power on/off ignition, software detectable
- Support S3, S4 suspend mode

Dimensions

- 185mm (W) x 120mm (D) x 50mm (H) (7.3" x 4.7" x 1.96")
- 1.1kg (2.42 lbs)

Construction

- Aluminum top case with sheet metal

Environment

- -40°C to 70°C (w/ industrial SSD) with air flow
- Storage temperatures: -40°C to 85°C
- Relative humidity: 10% to 90% (non-condensing)

Vibration (SSD):

Vibration (random): 2g @5~500 Hz

Operating: MIL-STD-810F, Method 514.5, Category 20, Ground Vehicle – Highway Truck

Storage: MIL-STD-810F, Method 514.5, Category 24, Integrity Test

Shock (SSD):

Operating: MIL-STD-810F, Method 516.5, Procedure I, Trucks and semi-trailers=20g

Crash hazard: MIL-STD-810F, Method 516.5, Procedure V, Ground equipment=75g

Standards/Certifications

- CE approval
- FCC Class A
- E13 mark

Ordering Information

♦ VTC 1020-PA (P/N: 10V00102000X0)

Intel Atom® x5-E3930 processor 1.3GHz with 4GB DDR3L, U-blox GPS module, GPS antenna and CAN 2.0B (BOM option SAE J1939), LVDS and 3 x Audio-in + 3 x Audio-out