

Main Features

- Intel® 11th Gen Tiger Lake UP3, cost-efficient performance
- Compact, rugged and fanless design
- Rich I/Os, 4 x PoE+, GbE, 4 x USB 3.2/2.0 & 2 x RS232/422/485
- 1 x 2.5" SSD, 1 x mSATA and 1 x NVMe SSD for data integrity
- Up to 3 combinations of LTE/5G, Wi-Fi 5/6 for mobile router function
- Triple display, VGA, HDMI and DP for multi video-out
- 9~36V DC-IN with ignition control & OCP/OVP
- Wide range operating temperature of -30°C~60°C (15W TDP & PoE)
- Military standard of anti-vibration/shock for OHV applications
- CE/FCC, UKCA, Emark Certified

Product Overview

VTC 7260-xC4 is an in-vehicle AI-aided telematics computer designed with Intel 11th Gen. Tiger Lake UP3, which performs 25% more computing power than the former generation. Moreover, its 10-year product lifespan can satisfy the long-term support suitable for any in-vehicle applications. With the compact, rugged, and fanless design, VTC 7260-xC4 can widely be installed in any limited cabinet space with ease, and reduce the maintenance efforts while operating 24/7 services. In addition, the VTC 7260-xC4 features diverse peripherals, such as 2.5GbE, PoE+, USB 3.2, isolation CANBus, serial ports, ultra-speed NVMe storage, triple displays, audio in/out, DI/DO, and 9~36VDC with IGN control, making it a sophisticated in-vehicle computer.

To work as the edge AI, the user can install LTE/5G/Wi-Fi 5/6 modules along with Hailo AI accelerator (26TOPS) to deploy AI services, provided from cloud SaaS. In consideration of the harsh environment applications, VTC 7260-xC4 can be operated at the temperature range of -30°C~60°C (15W TDP & PoE) and is compliant with MIL-STD-810G military standard for anti-vibration/shock. For the regulation, VTC 7260-xC4 is compliant with CE/FCC Class A, UKCA, and EMARK (E13).

Specifications

CPU

- Intel® Core™ 11th Gen Tiger Lake UP3
- Core i5-1145GRE, base frequency 1.5GHz/ 2.6GHz, 4c, 8 MB Intel® Smart Cache (VTC 7260-5C4)
- TDP boot mode in BIOS setting: nominal (15W)
- Core i7-1185GRE, base frequency 1.8GHz/ 2.8GHz, 4c, 12 MB Intel® Smart Cache (VTC 7260-7C4)
- Graphics:
 - Intel® Iris® X^e graphics, 1.3GHz
 - Max resolution: 4096 x 2304@60Hz (HDMI)
 - DirectX: 12.1, OpenGL: 4.6

Memory

- 2 x SO-DIMM, DDR4-3200MHz
- 4GB+4GB in default, 64GB in max.
- ECC (in-band ECC), dual-channel support

Storage

- 1 x 2.5" SSD (15mm height)
- 1 x mPCIe for mSATA (SATA 3.0)
- 1 x M.2 2242/2280 Key M NVMe SSD (PCIe 4.0 x4), Hailo AI card in option

Expansion slots

- 1 x mPCIe socket (PCIe 3.0 + USB 2.0/ USB 3.2), 2 x micro SIMs supported
- 1 x M.2 3042/3052 Key B socket (USB 3.2), 2 x micro SIMs supported
- 1 x M.2 2230 Key E socket (PCIe 3.0 x2 & USB 2.0), Wi-Fi or Hailo AI card in option)

Display

- 1 x HDMI 2.0a/b, up to 3840 x 2160@60Hz
- 1 x VGA, up to 2560 x 1600@60Hz

- 1 x DP, 4096 x 2304@60Hz

PoE+

- 4-port independent 2.5GbE, RJ45 connector
 - IEEE 802.3 af/at, total 60W
 - 9K byte jumbo frame
 - PTP (IEEE 1588) support
 - Controller: Intel® I225-IT

GbE

- 1-port independent GbE, RJ45 connector
 - vPro (iAMT) support
 - 9K byte jumbo frame
 - PTP (IEEE 1588) support
 - Wake-up function (WoL)
 - Boot from PXE (UEFI)

USB

- 3 x USB 3.2 Gen1:
 - Host type-A connector
 - 5V@900mA each
 - Up to 10Gbit/s link speed & compliance with USB 2.0 (LS/FS/HS link speed)
- 1 x USB 2.0, host type-A, 2 x USB 2.0 wafter-type reserved

Serial Port

- 2 x full RS232/422/485, selectable
- 2 x full RS232 wafer-type reserved
 - RS232 working voltage, +- 9V, baud rate up to 115.2kb/s

Security

- TPM 2.0: Infineon SLB9670VQ2.0 FW7.62

Dimension Drawing

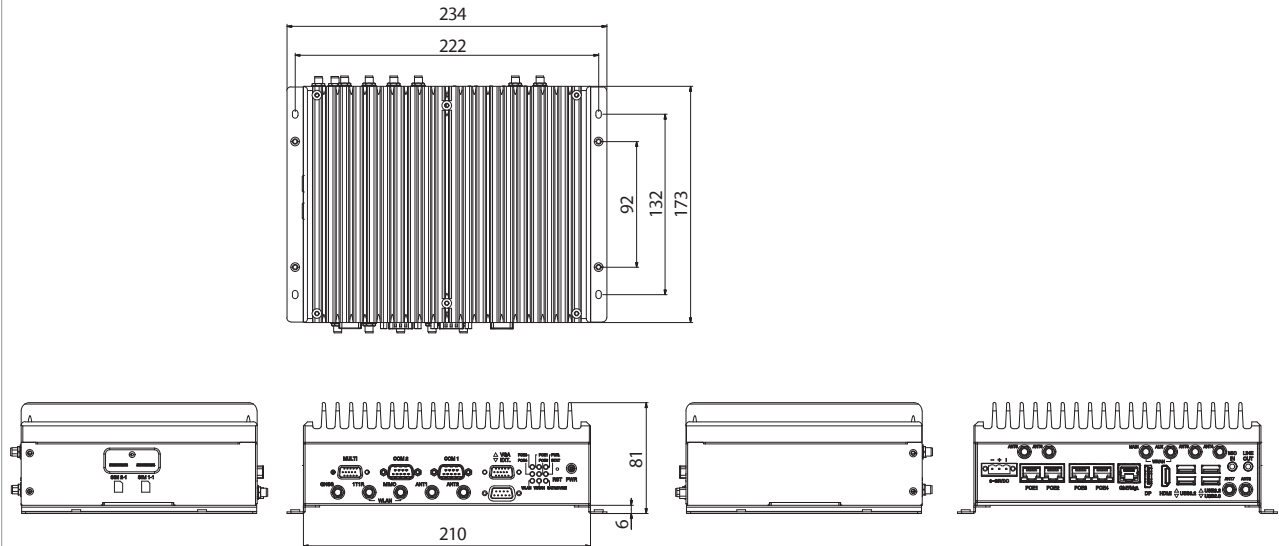

Audio

- Line-out, unbalance stereo, left & right channel
- MIC-in, stereo
- Line-in reserved (wafer connector)

MEMS Sensor

- 3D accelerometer and 3D gyroscope
- Controller: ST LSM6DSLTR

DI/DO

- 4-bit input
 - Source: 9~36VDC (12V@1.1mA/24V@2.2mA)
 - External: 0~33VDC pull-high, high-level, 3.3 - 33 VDC; low-level, 0 - 2 VDC
- 4-bit output
 - Source: 9~36VDC (nominal 35mA@24V):
 - External: 5~27VDC pull-high, sink current w/ 220mA for each bit, 500mA max (@25C)
- Source or external can be selected by DIP switch (default: source type)

CAN Bus

- 1 x CAN 2.0A/ 2.0B
- IEC 61000-4-2 Electrostatic Discharge (ESD): ± 8KV/15KV (contact/air)
- 2.5KV isolated

GNSS

- U-blox NEO-M9N GNSS module for GPS/GLONASS/QZSS/Galileo/Beidou
- Optional DR (Dead Reckoning) function, NEO-M8U/M8L

Power Supply

- Nominal voltage: 9~36V
- Cranking voltage: 6V~9V (less than 20 sec)
- OCP & UVP (shut down once exceeding 37V)
- Ignition on/off control & programmable on/off delay timer
- Optional for remote power on/off control

I/O Ports, Front-Plate

- ATX power button, Reset button
- 9 x LED Indicators, 1 x VGA (DB15), 2 x COM (DB9, RS232/422/485), 1 x Multi-port (DB15, 4xDI, 4xDO, CAN, DR signal), 1 x Ext. (DB15, reserved), 1 x PR-SMA for GNSS, 4 x PR-SMA for WLAN

I/O Ports, Rear-Plate

- 2 x Audio jack (Line-out & MIC-in)
- 3 x USB 3.2 type A, 1 x USB 2.0 type A
- 1 x HDMI, 1 x DP, 4 x PoE+ (2.5GbE, RJ45), 1 x GbE, 9~36VDC (3-pin Phoenix)
- 4 x SMA for WWAN, 4 x antenna holes reserved

I/O Ports, Side-Plate

- 2 x SIM slots (SIM1-1, SIM2-1)

Dimensions & Weight

- 210.0mm x 173.0mm x 75.0mm (w/o mount brackets)
- 234.0mm x 173.0mm x 81.0mm (w/ mount brackets)
- Weight: 3.1kg

Environment

- Operating temperatures: -30°C~60°C (15W TDP & PoE)
- Storage temperatures: -40°C~85°C
- Relative humidity: 10%~95% (non-condensing)

Vibration & Shock

- Vibration in operating:
 - MIL-STD-810H, 514.8C Procedure 6, Category 4
 - IEC 60068-2-64: 2.0g@5~500Hz
- Vibration in storage:
 - MIL-STD-810G, 514.6E Procedure 1, Category 24, 7.7g
- Shock:
 - MIL-STD-810G, 516.6 Procedure I, trucks and semi-trailers=40g
 - Crash hazard: Procedure V, ground equipment=75g

Certifications

- CE approval, FCC Class A, UKCA, E13 Certified

Operating System

- Windows 10 64-bit/Windows 10 IOT 64-bit, Windows 11
- Linux (Ubuntu 18.04)

External Cable (option)

- DB15 multi-port adapter cable, 20cm

Ordering Information

• VTC 7260-5C4 (P/N: 10V00726001X0)

Intel® Tiger-lake UP3 Core i5, 4 x PoE+, 1 x GbE, 1 x USB 2.0, 3 x USB 3.2, 2 x RS232/422/485, 1 x 2.5"SSD, 1 x mSATA, 9~36VDC/IGN

• VTC 7260-7C4 (P/N: 10V00726000X0)

Intel® Tiger-lake UP3 Core i7, 4 x PoE + 1 x GbE, 1x USB 2.0, 3 x USB 3.2, 2 x RS232/422/485, 1 x 2.5"SSD, 1 x mSATA, 9~36VDC/IGN