



VES 31-4SR



VES 31-8SR

## Main Features

- 4/8 x IEEE 802.3af/at-compliant Gigabit Ethernet ports, 120W
- 4/8 PoE+ standard+2 x Gigabit Ethernet ports with M12 X-coded connector
- Low battery voltage protection
- CE/FCC/UKCA/E-mark/EN 50155 class OT4 conformity
- Wide power input range 9~36VDC
- Jumbo frame support (up to 9216 Bytes)
- Ignition power on/off support
- Power on/off delay time setting

## Product Overview

VES 31-4SR/VES 31-8SR unmanaged mobile PoE switch is designed for telematics applications in harsh environments with fanless enclosure. It provides 6/10 Giga bit Fast Ethernet ports including 4/8 IEEE 802.3af/at compliance PoE+ ports to transfer large amounts of video streaming, voice and critical data across Ethernet network smoothly and quickly.

The mobile PoE switches support a wide voltage input range of 9VDC to 36VDC for the trains with 24VDC power system. VES 31-4SR/VES 31-8SR provide smart power management with low battery voltage protection, power-on and power-off delay timer, and auto ignition power on/off functions. These unique features can secure reliable operation and prevent premature failure of both the PoE switches and trains.

VES 31-4SR/VES 31-8SR are encased in a fanless dustproof enclosure and can operate under shock, vibration, and temperature extremes from -40 to 70°C. The mobile PoE switches are also small in size and support optional din rail mounting for ease of installation with PD devices such as IP cameras and Wi-Fi access points.

## Specifications

### Architecture

- Switch architecture. Highly integrated, unmanaged-smart gigabit, store and forward switch
- 2K entry MAC address table with 4-way hash algorithm

### Power over Ethernet

- PoE standard IEEE 802.3af/at power over Ethernet/PSE
- PoE power supply type end-span
- PoE power output per port 54V DC, 550mA. max. 30 watts

### Network Connector

- 4/8-port M12 X-coded for 10/100/1000 base-T. PoE IEEE 802.3af/at compliance, total 120W
- 2-port M12 X-coded for 10/100/1000 base-T

### Standard Compliance

- IEEE 802.3 for 10BaseT Ethernet
- IEEE 802.3u for 100BaseT(X) Fast Ethernet
- IEEE 802.3ab for 1000BaseT(X) Gigabit Ethernet
- IEEE 802.3x for flow control
- IEEE 802.3af/at Power Over Ethernet

### I/O Interface

- Power: 9~36VDC input with ignition for 24VDC railway system
- Ethernet
  - 4/8 x M12 X-coded 10/100/1000 Mbps PoE port, 802.3af/at compliance
  - 2 x M12 X-coded 10/100/1000 Mbps
- LED
  - 1 x power indicator
  - (For PoE) 4/8 x PoE indicator + 4/8 x Link/Active indicator
  - (For LAN) 2 x Active/Link indicator
  - 1 x low voltage protection indicator

### Power Management

- Selectable boot-up & shut-down voltage for low power protection by DIP switch
- Power on/off delay time setting by DIP switch

### Dimensions

- 211 x 89 x 140 mm (8.3"x3.5"x5.5.1") with wall mount bracket
- Weight: 1.3kg
- Support horizontal mounting, DIN-Rail mounting (option)

## Dimension Drawing

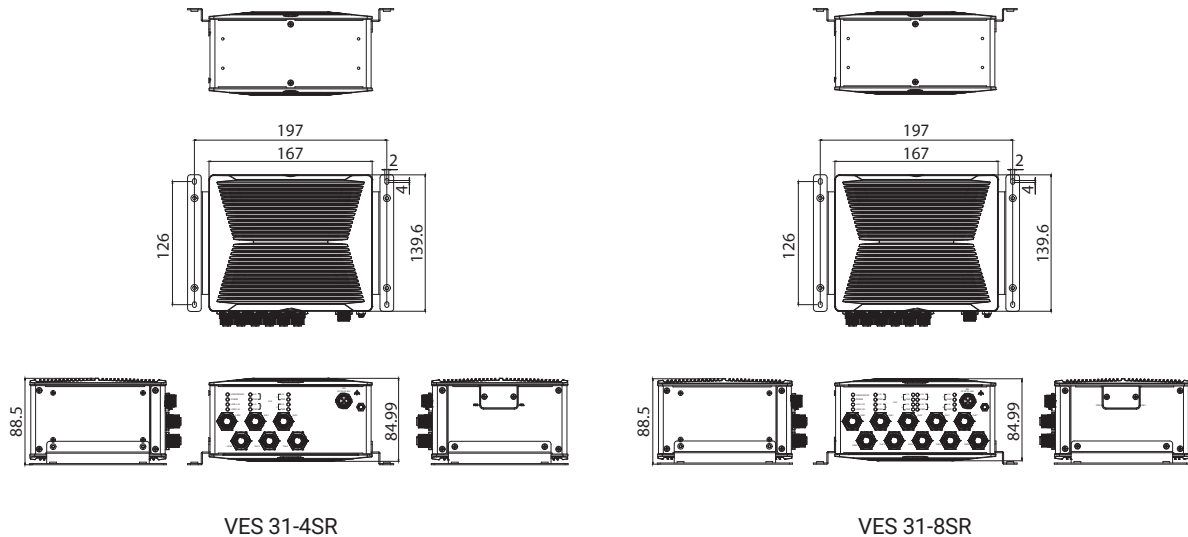

### Environment

- EN 50155, class OT4 (-40~70°C), 85°C for 10 minutes with air flow
  - Interruptions of voltage supply class S1
  - Supply change over class C1, C2
  - EMC EN 50121-1: 2017, EN 50121-3-2: 2016+A1: 2019
  - Environment EN 60068-2-1, EN 60068-2-2, EN 60068-2-30
  - Shock and vibration IEC 61373 Class B
  - Protective coating class PC1 (PC2, by request)
- Storage temperatures: -40°C to 85°C
- Relative humidity: 10% to 90% (non-condensing)
- Vibration (random): 2g@5~500 Hz
- Vibration:
  - Operating: MIL-STD-810H, Method 514.8C Procedure 1, Category 4, common carrier US highway truck vibration exposure
  - Storage: MIL-STD-810H, Method 514.8E Procedure 1, Category 24
- Shock:
  - Operating: MIL-STD-810H, Method 516.8 Procedure I, trucks and semitrailers=40g
  - Non-Operating: MIL-STD-810H, Method 516.8 Procedure V, crash hazard shock test=75g

### Standards/Certifications

- CE
- FCC Class A
- EN 50155
- UKCA
- E13 mark

### Ordering Information

- **VES 31-4SR (P/N: 10VE0003102X0)**  
4 x M12 X-Coded 10/100/1000 PoE port (802.3af/at), 2 x M12 X-coded 10/100/1000 Ethernet port, 9~36VDC input, ignition detection, low voltage protection, delay timer, EN50155
- **VES 31-8SR (P/N: 10VE0003103X0)**  
8 x M12 X-coded 10/100/1000 PoE port (802.3af/at), 2 x M12 X-coded 10/100/1000 Ethernet port, 9~36VDC input, ignition detection, low voltage protection, delay timer, EN50155