

## Main Features

- Intel® Core™ 8th Gen. desktop, i7-8700T, up to 4 GHz, 6 Core
- 1 x VGA and 1 x HDMI video output
- 2 x External SSD and 2 x mSATA (BIOS selection) for RAID 0, 1
- 3 x WWAN module slot, each for 2 x external SIM socket
- 4 x mini-PCIe slot and 1 x M.2 Key B slot
- CE/FCC/E mark
- Compliant with MIL-STD-810G
- Reserved M.2 slot for WWAN 5G modules

## Product Overview

NEXCOM mobile system VTC 7251 accomplishes operational efficiency of public transportation and service. Based on the 8th generation Intel®Core™ processors i7-8700T, VTC 7251 provides an integral solution incorporating high computing power, wireless communication (3 x WWAN + 6 x SIM) and GNSS tracking with optional Dead Reckoning (DR) support to record in-vehicle activities, locations, driving patterns, and vehicle diagnostics for buses and patrol vehicles achieving better measures for safety and management.

## Specifications

### CPU

- Intel® Core™ 8th Gen. i7-8700T, up to 4 GHz, 35W, 6 Core
- Compatible Intel® Core™ 9th Gen. (Coffee Lake Refresh)

### Chipset

- Intel® Q370 platform controller hub

### Memory

- 2-Channel 260-pin DDR4 SO-DIMM sockets up to 32GB/channel (64GB for two channels, non-ECC up to 2666 MHz), default 4GB + 4GB industrial grade memory

### Video Output

- Chipset Intel® UHD Graphics 630
- 1 x HDMI 1.4b up to 4096 x 2160 @ 30Hz
- 1 x VGA up to 1920 x 1200 @ 60Hz

### Storage

- 2 x 2.5" SATA 3.0 external SSD (compatible with 15mm height), RAID 0/1 supported
- 2 x mSATA 3.0 (BIOS selection)

### Expansion

- 1 x M.2 3042/3050/3052 (default) Key B socket (USB 2.0, USB 3.1) for LTE/5G NR module with dual SIM
- 1 x Full-size mini-PCIe socket (USB 2.0) for LTE with dual SIM
- Optional M.2 3042 Key B (USB 2.0, USB 3.1) for LTE/5G NR module
- 1 x Full-size mini-PCIe socket (USB 2.0) for LTE with dual SIM
- Optional M.2 3042 Key B (USB 2.0, USB 3.1) for LTE/5G NR module

- 1 x Full-size mini-PCIe socket (USB 2.0, PCIe 3.0 & SATA 3.0 [BIOS selection])
- 1 x Full-size mini-PCIe socket (USB 2.0, PCIe 3.0 & SATA 3.0 [BIOS selection])

### GNSS and On Board Sensor

- 1 x Default U-blox NEO-M8N GNSS module for GPS/Glonass/QZSS/Galileo/Beidou
- Optional modules with dead reckoning available
- TPM 2.0 by Infineon SLB9665TT2 (BOM option)
- G Sensor (3-axis, 10-bit resolution)

### Power over Ethernet

- 2x Independent LAN, 10/100/1000 Mbps. LAN1 support iAMT and WOL

### I/O Interface-Front

- 13 x LED indicators (including 4 x programmable LED)
- 4 x USB 3.1 type A (5V/1A)
- 6 x Externally accessible SIM card sockets (4 x WWAN + 8 x SIM, BOM option)
- 1 x Reset button
- 1 x Power button with LED
- 2 x 2.5" external SSD
- 11 x SMA antenna hole (GPS/WWAN/WLAN)

### I/O Interface-Rear

- 2 x RJ45 LAN port, 10/100/1000 Mbps

## Dimension Drawing

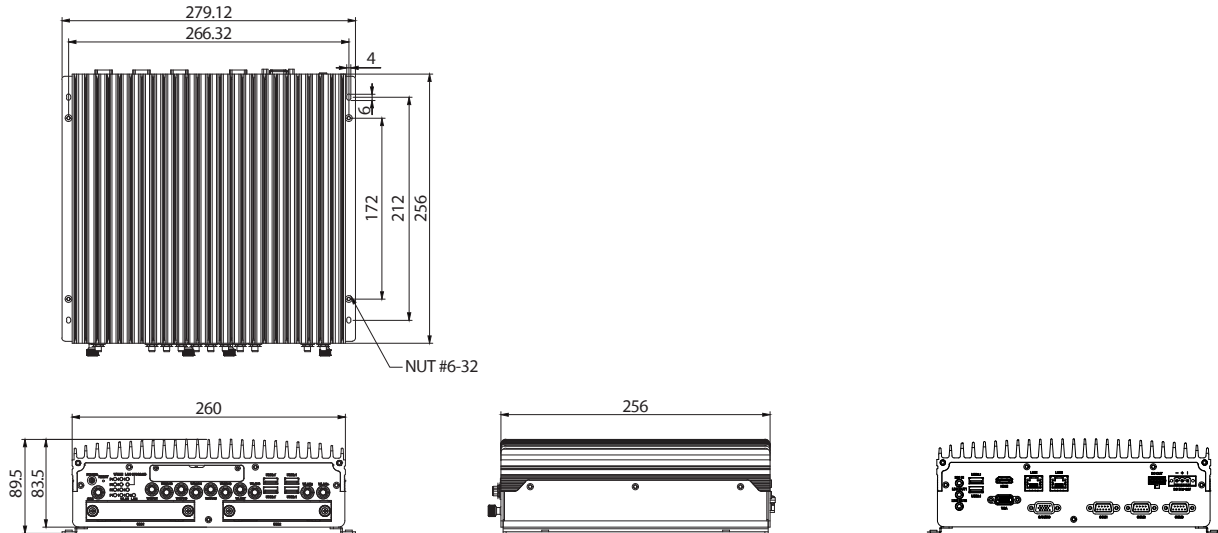

- ♦ 1 x 3-pin terminal block for 9V~36VDC
- ♦ 1 x Connector (4 x 2) for 12VDC/2A output, power button, 2 x MDI
- ♦ 1 x Mic-in, 2 x Line-out
- ♦ 2 x DB9 for full RS232
- ♦ 1 x DB9 for full RS232/422/485 (RI, 5V/0.5A, 12V/0.5A)
- ♦ 1 x DB15
  - 1 x Isolated CANBus 2.0B
  - 1 x GPS DR (option)
  - 4 x DI and 4 x DO
- ♦ 2 x USB 3.1 type A (5V/1A)
- ♦ 1 x HDMI 1.4b
- ♦ 1 x VGA

### Power Management & Software Support

- ♦ Power input 9~36VDC
- ♦ Cranking voltage: 6V~9V (< 30 seconds)
- ♦ Reverse protection, OCP & UVP
- ♦ Selectable boot-up & shut-down voltage for low power protection by software
- ♦ Setting 8-level power on/off delay time by software
- ♦ 10~255 seconds WDT support, setup by software
- ♦ SDK (Windows/Linux) including utility and sample code

### Operating System

- ♦ Windows 10
- ♦ Linux

### Dimensions

- ♦ 260 x 256 x 83.5 (W x D x H) (mm)

### Weight

- ♦ 4.2kg

### Environment

- ♦ Operating temperatures
  - -30°C~70°C (w/ industrial SSD) with air flow
- ♦ Storage temperatures: -40°C~80°C
- ♦ Relative humidity: 90% (non-condensing)
- ♦ Vibration (random)
  - 2g@5~500 Hz (in operation, SSD)
- ♦ Vibration (SSD)
  - Operating: MIL-STD-810G, Method 514.6, Category 4, common carrier US highway truck vibration exposure
  - Storage: MIL-STD-810G, Method 514.6, Category 24, minimum integrity test
- ♦ Shock (SSD)
  - Operating: MIL-STD-810G, Method 516.6, Procedure I, functional shock=40g
  - Non-operating: MIL-STD-810G, Method 516.6, Procedure V, crash hazard shock test=75g

### Certifications

- ♦ CE approval
- ♦ FCC Class A
- ♦ E-Mark (E13)

## Order Information

### ♦ VTC 7251 (P/N: 10V00725103X0)

Intel® Core™ 8th Gen. i7-8700T, 2 x 4 GB industrial grade memory, VGA & HDMI output, 2 x external SSD, 2 x LAN, 4 x mini-PCIe slot, 1 x M.2 slot, 6 x external SIM, 6 x USB 3.1, 2 x RS232 (full), 1 x full RS232/422/485, 4 x DI & 4 x DO