

# ATC 3540-IP7-4C/AI4CR

NVIDIA® Jetson Orin™ NX Solution  
Accelerated Edge AI Computing



ATC 3540-IP7-AI4CR



ATC 3540-IP7-4C

## Main Features

- Edge AI in-vehicle/rail computer
- Built-in NVIDIA® Jetson Orin™ NX SOM, up to 100 INT8 TOPS compute
- 4-port GbE PoE+ for IP CAM/LiDAR sensors
- HEVC/H.265 hardware CODEC, 18 x 1080p30 compute power (decoded)
- Wide range operating temperature of -30~70°C
- The rugged, fanless design with IP67 rating
- Ultra-speed PCIe 4.0 x4 NVMe SSD for data integrity
- NEXCOM Acceleration Linux (NAL) OS w/ JetPack 5.1.1 integrated
- Expandable for LTE/5G NR & Wi-Fi 5/6
- 9~36V DC-in with ignition control & OCP/OVP
- CE/FCC, UKCA, Emark/EN50155 certified

## Product Overview

AI has become an essential component of automated vehicle technologies. With built-in high performance/watt NVIDIA® Jetson Orin™ NX SOM, ATC 3540 can deliver up to 100 INT8 TOPS for running modern AI workloads while consuming 25W low power. This is suitable for AI power IoT gateway, OHV AI Edge recognition, AI traffic sign control, and factory automation/machine vision, enhancing productivity and lowering TCO.

ATC 3540 is a fanless, compact, and IP67 certified computer. It features 9~36VDC with IGN control, 4 PoE+ for IP CAM deployment to 4Kp30/1080p60. Moreover, ATC 3540 is designed with diverse peripheral ports, like USB 3.2, isolation CANBus, RS232, Console, DI/DO, OTG, and HDMI for connecting to a wide range of devices/sensors.

With the 5G NR, Wi-Fi 5/6 modules installed, ATC 3540 can enhance AI inference through Cloud Service Provider (CSP). As for harsh environment applications, ATC 3540 can operate at a wide range temperature of -30~70°C and meet the MIL-STD-810G military standard for vibration and shock resistance. In terms of regulation, ATC 3540 is compliant with CE/FCC Class A, UKCA and Emark (E13)/EN50155.

## Specifications

### NVIDIA® Jetson Orin™ NX SOM

- 8-core (Orin™ 16GB)/6-core (Orin™ 8GB) Arm® Cortex A78AE 64-bit CPU, 2GHz
- 1024-core + 32-core Tensor, 1.0GHz, Ampere
- 100 INT8 TOPS (Orin™ 16GB), 70 INT8 TOPS (Orin™ 8GB), sparse
- OpenGL 4.6, OpenGL ES 3.2, and Vulkan 1.1
- 260-pin SO-DIMM Form factor compatible with Xavier NX/TX2 NX
- NVIDIA® JetPack 5.1.1

### Memory

- 8GB/16GB 128-bit LPDDR5, 3200MHz

### Storage/Boot Disk

- 1 x M.2 2280/3080 Key M PCIe 3.0 x4 NVMe SSD

### Expansion

- 1 x Full size mPCIe socket (PCIe 4.0 + USB 2.0)
- 1 x M.2 3042/3052 Key B socket (USB 3.2) with 2 x micro SIM slots

### Display

- 1 x HDMI 2.0A/B, up to 3840 x 2160@60Hz

### G-Sensor

- 3D accelerometer and 3D gyroscope, ST LSM6DSLTR

### GbE

- 1-Port GbE, X-coded
- 9Kbyte Jumbo frame, PTP (IEEE 1588) support
- Controller: Intel® I210-IT

### PoE

- 4-Port Gbps, X-coded
- IEEE 802.3af/at compliant
- 30W (4-port) power budget in total
- PoE on/off and power watt monitoring
- The cap is pre-installed

### USB

- 2 x USB 3.2, type A
  - 5V@900mA each
  - up to 5Gbit/s link speed & compliance with USB 2.0 (LS/FS/HS link speed)
- 1 x OTG micro USB

### Serial Port

- 1 x RS232 (Tx, Rx, CTS, RTS)
- 1 x RS232 (Tx, Rx)
- 1 x Console port (Tx, Rx)
- RS232 working voltage, ±9V, baud rate up to 115.2kb/s

### DI/DO (reserved)

- 4-Bit input
  - Source: 9~36VDC (12V@0.6mA/24V@1.2mA)
  - External: 0~33VDC pull-high, high-level, 3.3 - 33VDC; low-level, 0-2 VDC
- 4-Bit output
  - Source: 9~36VDC (nominal 35mA@24V)
  - External: 5~27VDC pull-high, sink current w/ 220mA for each bit, 500mA max (@25C)
- Source or external can be selected by software (default: source type)

### CANBus

- 1 x CAN 2.0A/2.0B
- IEC 61000-4-2 Electrostatic Discharge (ESD): ±4KV/8KV (contact/air, whole system)
- 2.5KV isolated

## Dimension Drawing

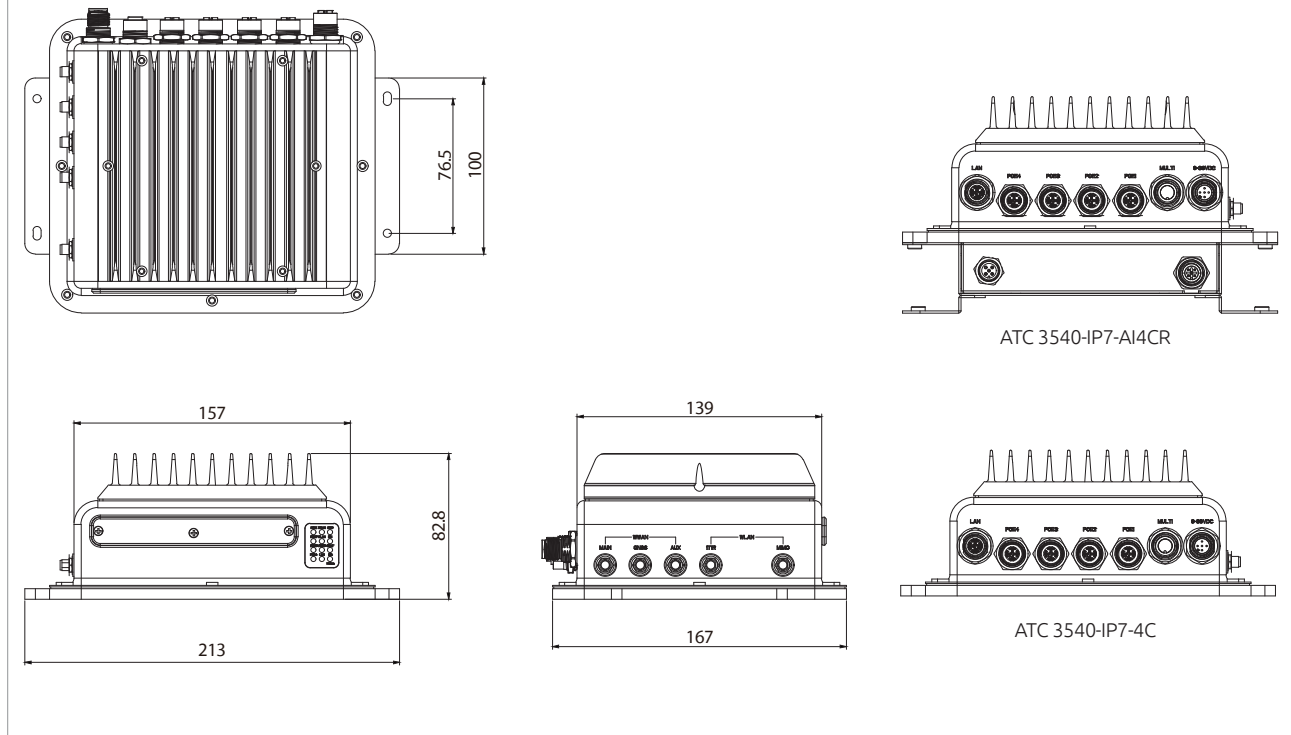

### GPS

- U-blox NEO-M9N GNSS module for GPS/Glonass/QZSS/Galileo/Beidou
- Optional DR (dead reckoning) function, NEO-M9V

### Power Supply

- Nominal voltage: ~9~36V (ATC 3540-IP7-4C); 24V for rail (ATC 3540-IP7-AI4CR)
- Cranking voltage: 6V~9V (less than 20 sec)
- OCP & UVP (shut down once exceeding 37V)
- Ignition on/off control & programmable on/off delay timer
- Opional for remote power on/off control

### I/O Ports, Front-Plate

- 12 x LED indicators
- Reset button, 1 x OTG
- 2 x Micro SIM slots, 1 x HDMI, 2 x USB 3.2

### I/O Ports, Rear-Plate

- 9~36VDC-in, S-coded
- 4 x GbE PoE & 1 x GbE, X-coded
- M12 multi-port (2 x RS232 & 1 x console, 1 x CAN)

### I/O Ports, Side-Plate

- 2 x antenna holes for Wi-Fi 5/6 modules (PR-SMA ant.)
- 2 x antenna holes for LTE/5G module (SMA ant.)
- 1 x antenna hole for GNSS (RP-SMA ant.)

### Dimensions & Weight

- ATC 3540-IP7-4C
  - 213mm x 167mm x 82.8mm (w/ mount bracket)
  - 2.4kg
- ATC 3540-IP7-AI4CR
  - 213mm x 167mm x 122.8mm (w/ mount bracket)
  - 3.2kg

### Environment

- Operating temperatures: -30°C~70°C NVIDIA® Jetson Orin™ NX@10W~25W, w/ 30W PoE)
- Storage temperatures: -40°C~85°C
- Relative humidity: 10%~95% (non-condensing)

### Vibration & Shock

- Vibration in operating
  - MIL-STD-810G, 514.6C, Procedure 3, Category 4
  - IEC 60068-2-64: 2.0g@5~500 Hz
  - MIL-STD-810G, 514.6E, Procedure 1, Category 24, 7.7g approx.

### Shock

- Operating: MIL-STD-810G, Method 516.6, Procedure I, functional shock=20g
- Non-operating: MIL-STD-810G, Method 516.6, Procedure V, crash hazard shock test=75g

### Certifications

- CE approval, FCC Class A, UKCA
- E13 (ATC 3540-IP7-4C)
- EN50155 (ATC 3540-IP7-AI4CR)

### Operating System

- NEXCOM Acceleration Linux (NAL)
  - NV Jetpack 5.1.1 package
  - NEXCOM custom functions (GNSS, 5G NR, 6-axis sensor, MCU control)
  - Ubuntu 20.04@Kernel 5.10

### External Cable

- Power extension cable, 20cm
- M12 multi-port adapter cable, 20cm

## Ordering Information

- **ATC 3540-IP7-4C (P/N: 10AT0354000X0)**  
IP67 rating AI edge compute, NVIDIA® Jetson Orin™ NX SOM, 8GB LPDDR5, 128GB NVMe, 4 x GbE PoE, 1 x GbE, 2 x RS232, 2 x USB 3.2
- **ATC 3540-IP7-AI4CR (P/N: 10AT0354001X0)**  
IP67 rating AI edge compute, NVIDIA® Jetson Orin™ NX SOM, 8GB LPDDR5, 128GB NVMe, 4 x PoE+ (X-coded), 1 x GbE (X-coded), 2 x USB 3.2, 24VDC w/ power isolation, rail
- **ATC 3540-IP7-4C-16 (P/N: 10AT0354002X0)**  
IP67 rating AI edge compute, NVIDIA® Jetson Orin™ NX SOM, 16GB LPDDR5, 128GB NVMe, 4 x GbE PoE, 1 x GbE, 2 x RS232, 2 x USB 3.2
- **ATC 3540-IP7-AI4CR-16 (P/N: 10AT0354003X0)**  
IP67 rating AI edge compute, NVIDIA® Jetson Orin™ NX SOM, 16GB LPDDR5, 128GB NVMe, 4 x PoE+ (X-coded), 1 x GbE (X-coded), 2 x USB 3.2, 24VDC w/ power isolation, rail