



Main Features

- Onboard Intel Celeron® Processor N97 quad-core 2.0GHz or Atom® Processor x7211E dual-core 1.0GHz
- 2 x Display output, 1 x HDMI and 1 x DP port
- 3 x Intel® I226-IT 2.5GbE TSN LAN port; supports WoL, teaming and PXE
- Storage supports mSATA and M.2 SATA & PCIe x2 modules
- 1 x Mini PCIe Wi-Fi/LTE wireless module
- 2 x USB 3.2
- 2 x USB 2.0
- 2 x DB9 for RS-232/422/485
- 2 x DB9 for RS-232
- Support -40°C~70°C extended operating temperature
- Support 9~30V DC input; supports AT/ATX power mode

Product Overview

Powered by the latest generation of Intel Celeron® N97 Quad Core or Atom® x7211E Dual Core (formerly codenamed “Alder Lake – N”), NISE110-A01/A02 provides outstanding performance not only on computing but also on graphics, and it presents a brand new opportunity for both intelligent and industrial computing solutions. Featuring up to 16GB of DDR5 memory, it offers various storage device options, such as M.2 and Mini PCIe. The NISE 110 has high integration ability with 3 x 2.5GbE TSN LAN port, 4 x COM port (2x RS-232 and 2x RS-232/422/485), which makes it a real intelligent system for various applications such as factory automation applications, network applications (with optional Wi-Fi module and 5G/4G/LTE module) and communication applications (with optional GPIO, RS-232/422/485). For harsh environments, the NISE110 also provides extended operation temperature SKUs ranging from -40°C to 70°C.

Specifications

CPU Support

- A01: Onboard Intel Celeron® Processor N97 quad-core 2.0GHz
- A02: Onboard Intel Atom® x7211E dual-core 1.0GHz

Main Memory

- 1 x DDR5 4800 SO-DIMM socket, supports up to 16GB

Display Option

- Dual independent display: HDMI + DP

I/O Interface-Front

- ATX power on/off switch
- LED indicator: power status, RTC battery low, programmable
- 3 x Intel® I226-IT 2.5GbE TSN LAN port; supports WoL, teaming and PXE
- 2 x USB 3.2 port
- 1 x HDMI port
- 1 x DB9 for COM1, supports RS-232 only
- 1 x Optional I/F opening for optional function output or module interface use
 - 1 x or 2 x RS-232
 - 1 x 4140 GPIO

- 1 x or 2 x 1/2.5GbE LAN port (M.2 or Mini PCIe)
- 1 x 8180 DIO
- 2 x USB 2.0
- 1 x 3-pin DC input, supports +9 to 30V DC

I/O Interface-Rear

- 2 x USB 2.0 port
- 1 x 2-pin remote power on/off switch
- 1 x Display port
- 1 x DB9 for COM2, supports RS-232 only
- 2 x DB9 for COM3 & COM4, support RS-232/422/485 with auto flow control, BIOS setting

I/O Interface-Internal

- 4 x GPI and 4 x GPO (5V, TTL type)
- 1 x nano-SIM holder
- TPM 2.0
- Mic in / Line out (optional)

Storage Device

- 1 x Mini PCIe for mSATA
- 1 x M.2 Key B 2242/2280 for SATA/PCIe x2 SSD

Dimension Drawing

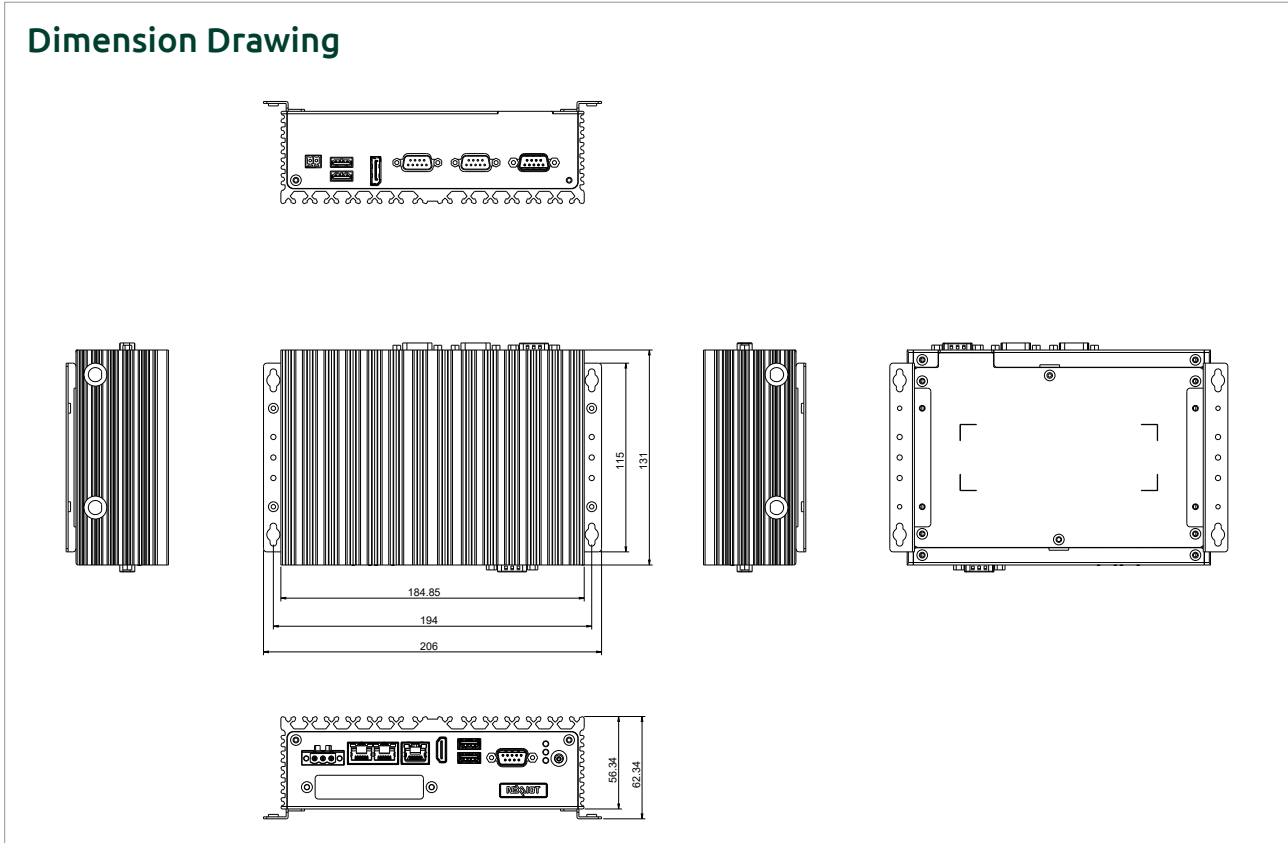

Expansion Slot

- 1 x Mini PCIe socket support optional Wi-Fi/4G LTE modules
- 1 x M.2 Key B socket support optional 5G/ 4G LTE/ Storage modules

Power Requirements

- Power input: +9 to 30V DC
- 1 x Optional 24V, 60W power adapter

Dimensions

- 185mm (W) x 131mm (D) x 56mm (H) without wall mount bracket

Construction

- Aluminum chassis with fanless design

Environment

- Operating temperature Ambient with air flow (according to IEC 60068 2 1, IEC 60068 2 2, IEC 60068 2 14)
 - A01: -40°C~60°C
 - A02: -20~60°C (UL approved), to 70°C (system limitation)
- Storage temperature: 40°C~80°C
- Relative humidity: 95% at 40°C
- Shock protection:
 - M.2/mSATA: 50G@wall mount, half sine, 11ms(operation), IEC 60068 2-27
- Vibration protection w/ M.2 & mSATA condition:
 - Random: 2Grms@5~500Hz, IEC 60068-2-64
 - Sinusoidal: 2Grms@5~500Hz, IEC 60068-2-6

Certifications

- CE approval
 - EN 61000-6-2
 - EN 61000-6-4
- FCC Class A
- UL

OS Support

- Windows 11
- Windows 10 IoT Enterprise, 64 bit
- Linux Kernel version 4.1

Ordering Information

- **NISE110 A01 system (P/N: 10J00011002X0)**
Intel Celeron® Processor N97 2.0GHz
- **NISE110 A02 system (P/N : 10J00011003X0)**
Atom® Processor x7211E 1.0GHz
- **24V, 60W AC to DC power adapter w/o power cord (P/N: 7400060054X00)**
- **24V, 120W AC to DC power adapter w/o power cord (P/N: 7400120029X00)**