

## Main Features

- Onboard Intel® Celeron® J3455 processor
- 1 x 204-pin SO-DIMM DDR3L
- Two display: 2 x HDMI and eDP (Optional: LVDS)
- 1 x M.2 2242 Key M
- 2 x RJ45 LAN with LED for Gigabit Ethernet
- 2 x USB 3.0, 2 x USB 2.0, Speaker-out, Mic-in
- Serial port: 1 x RS232, 1 x RS232/422/485 port
- Support AT/ATX mode and 12Vdc/19Vdc input

## Product Overview

X101 is under the 3.5" SBC series which is based on multi-core SoC Intel® Celeron® processor (formerly codenamed "Apollo Lake"). X101 series operates with low power consumption. This series of 3.5-inch board is aimed at embedded applications. It supports a maximum memory of 8GB DDR3L SDRAM. Also, it offers two display outputs of dual 4K HDMI and eDP or LVDS in order to provide the flexibility of supporting a range of peripherals. The X101 series is ideal for battery-powered portable devices, multimedia HDMI panels, home automation and thin clients.

## Specifications

### CPU Support

- Intel® Celeron® processor J3455 (F1 stepping), type 3 BGA, 31mm x 24mm, TDP: 10W

### Main Memory

- 1 x 204-pin SO-DIMM socket, support up to DDR3L 1600MHz, non-ECC, un-buffered memory up to 8GB

### BIOS

- AMI system BIOS
- Plug and play support

### Display

- 2 x HDMI 1.4b connector (resolution up to 3840 x 2160 @30Hz)
- eDP interface (Optional : LVDS)

### Storage

- 1 x M.2 2242 Key M

### Audio

- Realtek ALC3236 HD codec
- Pin header for Speaker out (2W 4Ω)
- Pin header for Mic-in, Line-out

### Onboard LAN

- 2 x Realtek RTL8111H GbE controller
- Support wake on LAN function

### Expansion Slot

- 1 x mini-PCIe full-size connector, support Wi-Fi and LTE
- 1 x SIM slot onboard (nano size)

### Power Requirements

- AT/ATX mode (by jumper setting default-AT)
- 2-pin power connector for DC power input
- Support 19Vdc/12Vdc input

### I/O

- 2 x USB 3.0
- 4 x USB 2.0
- 2 x Serial port
  - COM1: RS232/422/485
  - COM2: RS232 (R)/5V/12V)
- LVDS inverter connector: Pin header 2x3
- Back light control: 1 x 3P, S/T, 2.0mm, header
- LVDS resolution switch: 1 x 4 switch
- LED connector: Pin header
- GPIO 4 lines

## Block Diagram

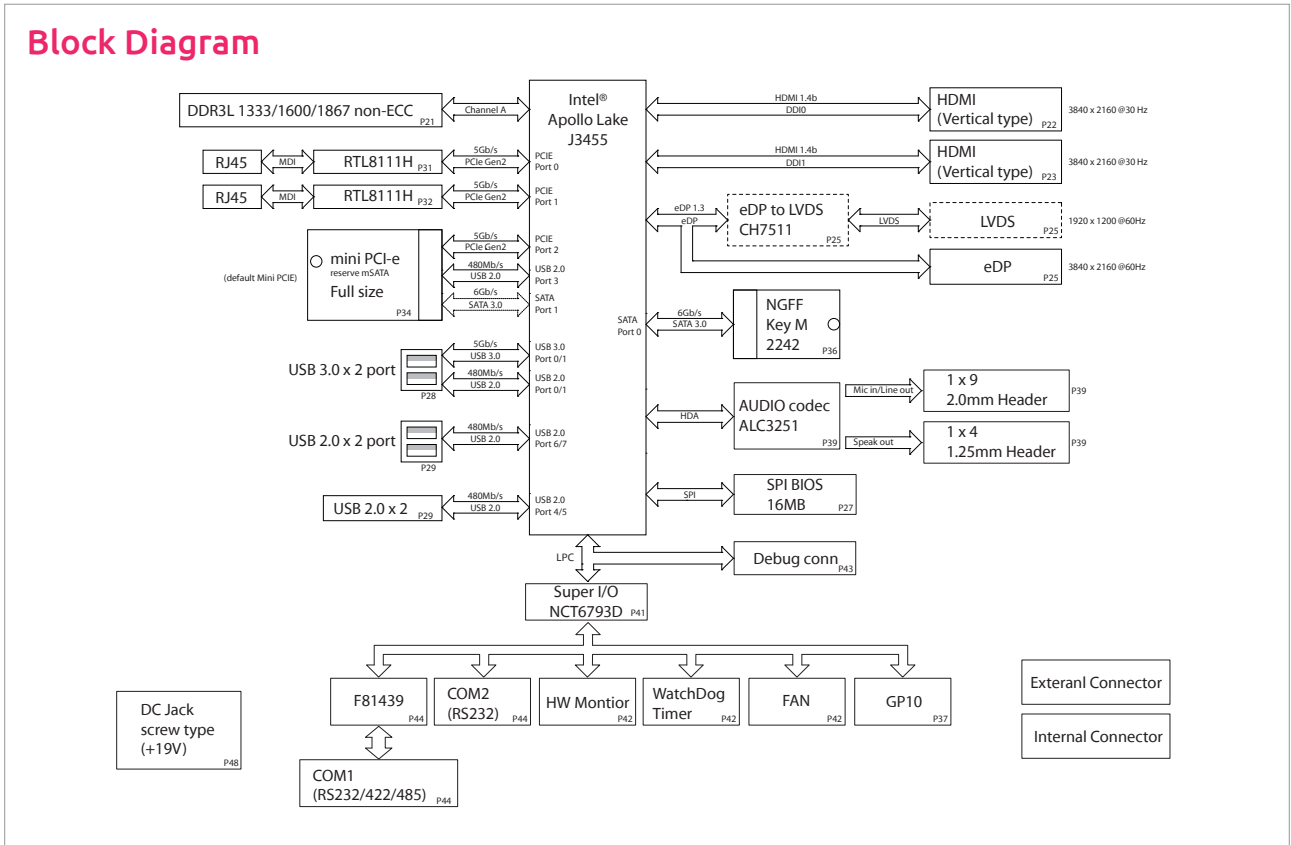

### Dimensions

- 146mm (L) x 102mm (W) (5.7" x 4.0")

### Environment

- Ambient operating temperature: 0~60°C

### Relative Humidity

- 10%~90% (operating, non-condensing)
- 5%~95% (non-operating, non-condensing)

### Certifications

- CE
- FCC Class A

## Ordering Information

### ♦ X101-J3455-E (P/N: 10W10X10103X0)

Embedded board with Intel® Celeron® processor J3455 with 2 x HDMI 1.4b, 2 x USB 3.0, 2 x USB 2.0, 2 x COMs, 1 x M.2 Key M, 2 x Gigabit LAN, 1 x mini-PCIe, 1 x eDP