



## Main Features

- 13/12th Gen Intel® Core™ i9/i7/i5/i3 processors, up to 35W
- Dual channel DDR5 SO-DIMM, max up to 64GB
- Support 3 x HDMI 2.0 output, 4K@60Hz
- Dual Intel® LAN ports
- Rich Interface : 2 x COM ports, 8 x USB port, Mic-in, Line-out
- TPM 2.0 onboard
- Support Intel® AMT technology (Q670E only)
- Multiple expansion slots: M.2 2280 Key M for storage, M.2 2230 Key E for Wi-Fi module, M.2 3052 Key B for LTE/5G module
- Power Input: 12V DC or 12~24V DC (Q670E only)

## Product Overview

The Neu-X304 series is an industrial grade fanless edge computing system powered by 13/12th Gen Intel® Core™ i9/i7/i5/i3 processors (formerly Alder Lake S & Raptor Lake-S) with Intel® 670E/H610E express chipset. In addition to the great computing performance, the Neu-X304 series features with outstanding GPU performance driven by Intel® UHD Graphics 770 engine allow for eye-catching visuals. The Neu-X304 system supports 3 x HDMI output, 4K@60Hz, and with rich I/O connectivity including 2 x LAN s (1 x Intel 226-V, 2.5GbE, 1 x Intel 219-LM, GbE), 2 x COM ports, 8 x USB ports, 1 x MIC-in, 1 x Line-out, and 1 x remote switch. It also comes in great expansion possibilities, including three M.2 slots for support SSD storage, Wi-Fi and LTE /5G connectivity. The Neu-X304 system offer a blend of AI and visual edge computing performance and efficiency and it's the perfect one for versatile application in industry, such healthcare service, public transportation monitoring, digital educational system, AI recognition and data center cloud computing.

## Specifications

### CPU Support

- 13/12th Gen Intel® Core™ i9/i7/i5/i3 processors, up to 35W
  - Intel® Core™ i9-12900TE, 16 core, 1.1 GHz (P-Core) and 1GHz (E-Core), 30M Cache, 35W
  - Intel® Core™ i7-12700TE, 12 core, 1.4 GHz (P-Core) and 1GHz (E-Core), 25M Cache, 35W
  - Intel® Core™ i5-12500TE, 6 core, 1.9 GHz (P-Core), 18M Cache, 35W
  - Intel® Core™ i3-12100TE, 4 core, 2.1 GHz (P-Core), 12M Cache, 35W
  - Intel® Core™ i9-13900TE, 16 core, 1.0 GHz (P-Core) and 800MHz (E-Core), 36M Cache, 35W
  - Intel® Core™ i7-13700TE, 16 core, 1.1 GHz (P-Core) and 800MHz (E-Core), 30M Cache, 35W
  - Intel® Core™ i5-13500TE, 14 core, 1.3 GHz (P-Core) and 1.1GHz (E-Core), 24M Cache, 35W
  - Intel® Core™ i3-13100TE, 4 core, 2.4 GHz (P-Core), 12M Cache, 35W

### Chipset & Memory

- Intel® PCH Q670E
- Intel® PCH H610E
- 2 x 262-pin DDR5 SO-DIMM socket, supports up to 64GB

### Graphic & Display

- Intel® UHD Graphics 770
- 3 x HDMI 2.0 output, resolution up to 4096 x 2160@60Hz
- 1 x LVDS connector, resolution up to 1920 x 1200@60Hz (Co-lay with eDP signal select by jumper, Q670E only)

### I/O Interface on the Front

- 1 x Power Button
- 1 x HDD LED Indicator
- 2 x COM ports:
  - COM1: RS232/422/485
  - COM2: RS232, support RI/12V/5V, select by jumper
  - COM3: RS232/422/485
  - COM4: RS232 (COM3 & COM4 are optional by request)
- 4 x USB 2.0 ports
- 1 x Remote ON/OFF switch

## Dimension Drawing

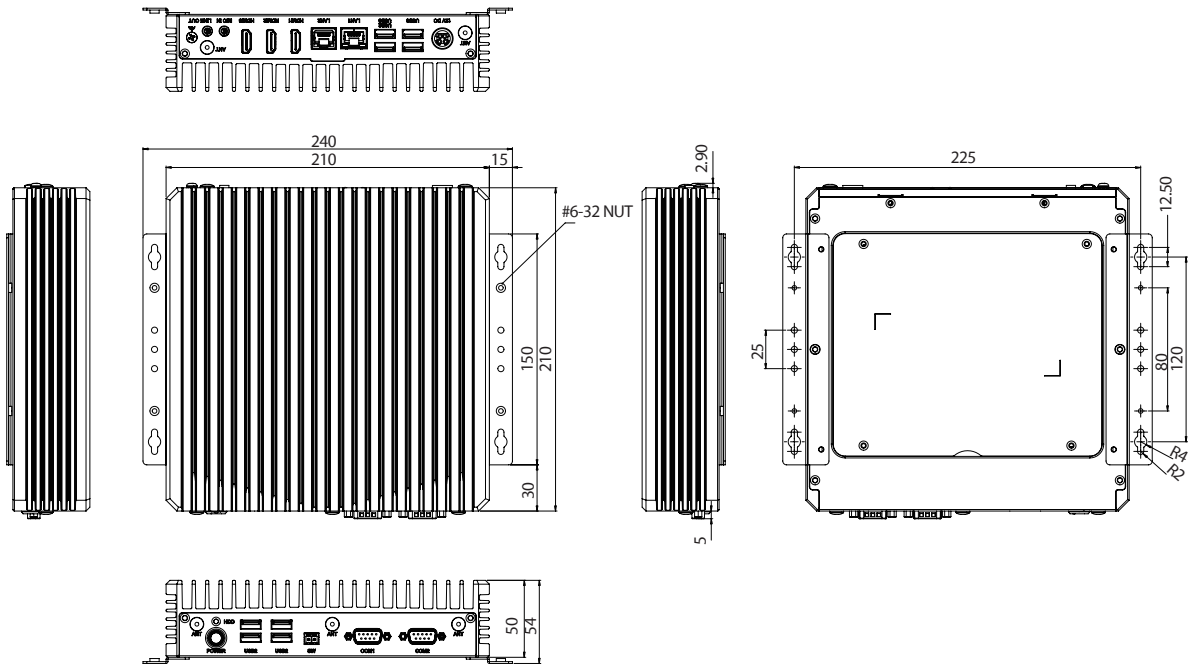

### I/O Interface on the Rear

- 1 x DC Jack
- 4 x USB 3.2 (Q670E) or 3 x USB 3.2+1 x USB 2.0 (H610E)
- 1 x Intel® i219-LM(GbE) , 1 x Intel® i226-V (2.5GbE)
- 3 x HDMI 2.0 output
- 1 x Mic-in, 1 x Line-out powered by Realtek ALC888S

### Internal I/O Function

- 1 x GPIO, TTL level, 4 x GPI, 4 x GPO
- 1 x Internal speaker pin header with 2W 4Ω Amplifier
- 2 x Reserved COM ports ( by request):
  - COM 3: RS232/422/485
  - COM 4: RS232

### Expansion

- 1 x M.2 2230 Key E, support Wi-Fi 6/6E+bluetooth module
- 1 x M.2 3052 Key B, support LTE/5G module

### Storage

- 1x M.2 2280 Key M, support PCIe x4 and SATA signal

### Power Requirements

- Neu-X304-Q: 12-24V DC, max up to 120W
- Neu-X304-H: 12V DC only, max up to 120W

### Environment

- Operating temperature: -5°C to 45°C (according to IEC60068-2-1, IEC60068-2-2, IEC60068-2-14)
- Relative humidity (non-condensing): 95% (non-condensing)
- Storage temperature: -20°C to 80°C
- Shock protection: 50G peak acceleration, 11ms according to IEC60068-2-27
- Vibration protection
  - Random: 2Grms@5~500 Hz, IEC60068-2-64
  - Sinusoidal: 2G@5~500 Hz, IEC60068-2-6

### Certification

- CE approval (EN55032/EN55035)
- FCC Class A

### Mechanical & Dimension

- Aluminum and metal chassis with fanless design
- 240mm(L) x 210(W) x 54mm (H) with mounting bracket
- 210mm(L) x 210(W) x 50mm (H) w/o mounting bracket

### Operating System

- Win10/Win11/Linux

## Ordering Information

- **Neu-X304-Q (P/N: 10W10X30405X0)**  
13/12th Gen Intel® Core™ Edge Computing fanless system w/ Intel® PCH Q670E, 3 x HDMI, 12-24V DC
- **Neu-X304-H (P/N:10W10X30401X0)**  
13/12th Gen Intel® Core™ Edge Computing fanless system w/ Intel® PCH H610E, 3 x HDMI, 12V DC only