



ATC3520-IP7-4C-AI4CR



ATC 3520-IP7-4C

Main Features

- Edge AI in-vehicle/rail computer
- Built-in NVIDIA® Jetson Orin™ Nano SOM, up to 40(sparse) INT8 TOPS compute
- 4-Port GbE PoE+ for IP CAM/LiDAR sensors
- HEVC/H.265 hardware CODEC, 11x 1080p30 compute power (decoded)
- Wide range operating temperature of -30~70°C
- The rugged, fanless design with IP67 rating
- Ultra-speed PCIe 4.0 x4 NVMe SSD for data integrity
- NEXCOM Acceleration Linux (NAL) OS w/ JetPack 5.1.1 integrated
- Expandable for LTE/5G NR & Wi-Fi 5/6
- 9~36V DC-in with ignition control & OCP/OVP
- CE/FCC, UKCA, EN50155 certified

Product Overview

AI has become an essential component of automated vehicle technologies. With built-in cost-effective performance/watt-cost NVIDIA® Jetson Orin™ Nano SOM, ATC 3520 can deliver up to 40(sparse)INT8 TOPS for running modern AI workloads while consuming 15W low power. This is suitable for AI power IoT gateway, OHV AI Edge recognition, AI traffic sign control, and factory automation/machine vision, to enhance the productivity and lowering TCO.

ATC 3520 is a fanless, compact, and IP67 certified computer. It features 9~36VDC with IGN control, 4 PoE+ for IP CAM deployment to 4Kp30/1080p60. Moreover, ATC 3520 is designed with diverse peripheral ports, like USB 3.2, isolation CANBus, RS232, Console, DI/DO, OTG, and HDMI for connecting to a wide range of devices/sensors.

With the 5G NR, Wi-Fi 5/6 modules installed, ATC 3520 can enhance AI inference through Cloud Service Provider (CSP). As for harsh environment applications, ATC 3520 can operate at a wide range temperature of -30~70°C and meet the MIL-STD-810G military standard for vibration and shock resistance. In terms of regulation, ATC 3520 is compliant with CE/FCC Class A, UKCA and Emark (E13)/EN50155.

Specifications

NVIDIA® Jetson Orin™ Nano SOM

- 6-core (Orin™ Nano 8GB/4GB) Arm® Cortex A78AE 64-bit CPU
- 512/1024-core + 16/32-core Tensor, 625MHz, Ampere
- 40 INT8 TOPS (Orin™ Nano 8GB), 20 INT8 TOPS (Orin™ Nano 4GB), sparse
- OpenGL 4.6, OpenGL ES 3.2, and Vulkan 1.1, CUDA10
- 260-pin SO-DIMM form factor compatible with Orin NX
- NVIDIA® JetPack 5.1.1

Memory

- 4GB/8GB 64-bit/128-bit LPDDR5 for Nano 4GB/8GB 2133 MHz

Storage/Boot Disk

- 1 x M.2 2280/3080 Key M PCIe 3.0 x4 NVMe SSD, 128GB in default

Expansion

- 1 x Full size mPCIe socket (PCIe 4.0 + USB 2.0)
- 1 x M.2 3042/3052 Key B socket (USB 3.2) with 2 x micro SIM slots

Display

- 1 x HDMI 2.0A/B, up to 3840 x 2160@60Hz

G-Sensor

- 3D accelerometer and 3D gyroscope, ST LSM6DSLTR

GbE

- 1 port GbE, X-coded
- 9Kbyte Jumbo frame, PTP (IEEE 1588) support
- Controller: Intel® I210-IT

PoE

- 4-Port Gbps, X-coded
- IEEE 802.3af/at compliant
- 30W (4-port) power budget in total
- PoE on/off and power watt monitoring

USB

- 2 x USB 3.2, type A
 - 5V@900mA each
 - up to 5Gbit/s link speed & compliance with USB 2.0 (LS/FS/HS link speed)
- 1 x OTG micro USB, 2 x USB2.0 wafer-type (reserved)

Serial Port

- 1 x RS232 (Tx, Rx, CTS, RTS)
- 1 x RS232 (Tx, Rx)
- 1 x Console port (Tx, Rx)
- RS232 working voltage, ±9V, baud rate up to 115.2kb/s

DI/DO (reserved)

- 4-Bit input
 - Source: 9~36VDC (12V@0.6mA/24V@1.2mA)
 - External: 0~33VDC pull-high, high-level, 3.3 - 33VDC; low-level, 0-2 VDC
- 4-Bit output
 - Source: 9~36VDC (nominal 35mA@24V)
 - External: 5~27VDC pull-high, sink current w/ 220mA for each bit, 500mA max (@25C)
- Source or external can be selected by software (default: source type)

CANBus

- 1 x CAN 2.0A/2.0B
- IEC 61000-4-2 Electrostatic Discharge (ESD): ±4KV/8KV (contact/air, whole system)
- 2.5KV isolated

Dimension Drawing

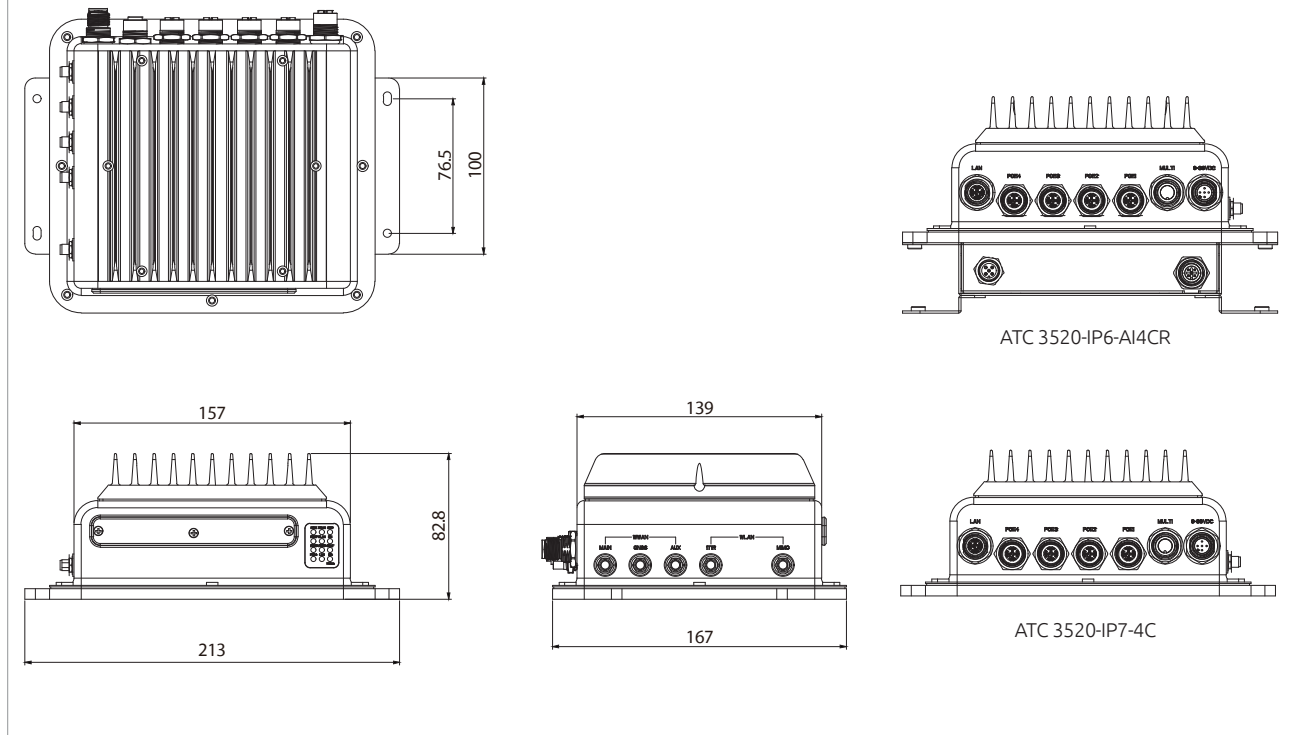

GPS

- U-blox NEO-M9N GNSS module for GPS/Glonass/QZSS/Galileo/Beidou
- Optional DR (dead reckoning) function, NEO-M9V

Power Supply

- Nominal voltage: ~9~36V (ATC 3520-IP7-4C); 24V for rail (ATC 3520-IP7-AI4CR)
- Cranking voltage: 6V~9V (less than 20 sec)
- OCP & UVP (shut down once exceeding 37V)
- Ignition on/off control & programmable on/off delay timer
- Opional for remote power on/off control

I/O Ports, Front-Plate

- 12 x LED indicators
- Reset button, 1 x OTG
- 2 x Micro SIM slots, 1 x HDMI, 2 x USB 3.2

I/O Ports, Rear-Plate

- 9~36VDC-in, S-coded
- 4 x GbE PoE & 1 x GbE, X-coded
- M12 multi-port (2 x RS232 & 1 x console, 1 x CAN)

I/O Ports, Side-Plate

- 2 x Antenna holes for Wi-Fi 5/6 modules (PR-SMA ant.)
- 2 x Antenna holes for LTE/5G module (SMA ant.)
- 1 x Antenna hole for GNSS (RP-SMA ant.)

Dimensions & Weight

- ATC 3520-IP7-4C
 - 213mm x 167mm x 82.8mm (w/ mount bracket)
 - 2.4kg
- ATC 3520-IP7-AI4CR
 - 213mm x 167mm x 122.8mm (w/ mount bracket)
 - 3.2kg

Environment

- Operating temperatures: -30°C~70°C NVIDIA® Jetson Orin™ Nano@7W/10W15W, w/ 30W PoE)
- Storage temperatures: -40°C~85°C
- Relative humidity: 10%~95% (non-condensing)

Vibration & Shock

- Vibration in operating
 - MIL-STD-810G, 514.6C, Procedure 3, Category 4
 - IEC 60068-2-64: 2.0g@5~500 Hz
 - MIL-STD-810G, 514.6E, Procedure 1, Category 24, 7.7g approx.
- Shock
 - Operating: MIL-STD-810G, Method 516.6, Procedure I, functional shock=20g
 - Non-operating: MIL-STD-810G, Method 516.6, Procedure V, crash hazard shock test=75g

Certifications

- CE approval, FCC Class A, UKCA
- EN50155 (ATC 3520-IP7-AI4CR)

Operating System

- NEXCOM Acceleration Linux (NAL)
 - NV Jetpack 5.1.1 package
 - NEXCOM custom functions (GNSS, 5GNR, 6-axis sensor, MCU control)
 - V4L2
 - Ubuntu 20.04@Kernel 5.10

External Cable

- Power extension cable, 20cm
- M12 multi-port adapter cable, 20cm

Ordering Information

- **ATC 3520-IP7-4C (P/N: 10AT0352000X0)**
IP67 rating edge AI compute, NVIDIA® Jetson Orin™ Nano SOM, 4GB LPDDR5, 128GB NVMe, 4 x GbE PoE, 1 x GbE, 2 x RS232, 2 x USB 3.2
- **ATC 3520-IP7-AI4CR (P/N: 10AT0352001X0)**
IP67 rating edge AI compute, NVIDIA® Jetson Orin™ Nano SOM, 4GB LPDDR5, 128GB NVMe, 4 x PoE+ (X-coded), 1 x GbE (X-coded), 2 x USB 3.2, 24VDC w/ power isolation, rail