



nROK 7252-AC8S



nROK 7252-WI2-C8S

## Main Features

- Intel® Coffee Lake S/Refresh 8th/9th Gen Core™/Xeon® LGA1151 socket-type CPU
- Six SIM cards + three WWAN modules support
- LTE/5G WWAN module support
- 2/4 x External SSD for RAID 0, 1, 5, 10 (compatible with 15mm disk)
- 2 x mSATA (occupied mini-PCIe slot)
- EN 50155, class OT4 conformity
- Three video outputs, one VGA and two HDMI
- 3 x mini-PCIe + 2 x M.2 socket expansion
- 1 x SD card for exporting and backing up data
- Wide voltage input 24~110VDC (w/ isolation) (nROK 7252-WI2-C8S)
- Up to 3-sec protection against temporary voltage dips (nROK 7252-WI2-C8S)

## Product Overview

NEXCOM system nROK 7252 accomplishes operational efficiency of public transportation and service. Based on Intel® Coffee Lake S/Refresh 8th/9th Gen Core™/Xeon® LGA1151 socket-type CPU and 8-port 802.3 af/at PoE, it provides an integral solution incorporating high computing power. with dual SIM cards per modem support, it allows six SIM cards backup each other for a better connectivity quality by software. In addition, six SIM cards and three WWAN modules architecture can increase the bandwidth for a faster data transmission speed. RAID 0, 1, 5, 10 guarantees the safety of data in the 2/4 x external SSD. nROK 7252 keeps the flexibility to meet the demand for different rolling stock applications, such as infotainment, transportation cellular router, video server, and video surveillance.

## Specifications

### CPU

- Support 9th/8th generation Intel® Core™ i7/i5/i3, Xeon® LGA1151 socket
  - Intel® Core™ i7-9700TE/i7-8700T, TDP 35W
  - Intel® Core™ i5-9500TE/i5-8500T, TDP 35W
  - Intel® Core™ i3-9100TE/i3-8100T, TDP 35W
  - Intel® Xeon® E-2278GEL, TDP 35W
  - Intel® Celeron® G4900T, TDP 35W

### Chipset

- Intel® C246 platform controller hub

### Memory

- 2 x 260-pin DDR4 SO-DIMM sockets up to 32GB/channel (64GB for two channels)
- ECC memory to support: i3-9100TE/i3-8100T, E-2278GEL, G4900T

### Video Output

- Chipset Intel® UHD graphics 630
- 2 x HDMI 1.4b up to 4096 x 2160 @ 30Hz
- 1 x VGA up to 1920 x 1200 @ 60Hz

### Storage

- nROK 7252-AC8S: 4 x 2.5" SATA 3.0 external SSD (15mm)
- nROK 7252-WI2-C8S: 2 x 2.5" SATA 3.0 external SSD (15mm)
- 2 x mSATA (occupied mini-PCIe slot)
- 1 x Removable SD 3.0

### Expansion

- 1 x Full size mini-PCIe socket (USB 2.0, PCIe 3.0/SATA)
- 1 x Full size mini-PCIe socket (USB 2.0, PCIe 3.0/SATA), BOM optional
- M.2 3042 Key B socket (USB 2.0, USB 3.1 Gen 1) for LTE/5G NR module with 2 x external SIM

- 1 x Full size mini-PCIe socket (USB 2.0, USB 3.1 Gen 2 (BOM optional)) for LTE module, BOM optional M.2 3042/3050/3052 Key B socket (USB 2.0, USB 3.1 Gen 2, PCIe 3.0 (BOM optional)) for LTE/5G NR module with 2 x external SIM
- 2 x M.2 3042/3050/3052 Key B socket (USB 2.0, USB 3.1 Gen 2, PCIe 3.0 (BOM optional)) for LTE/5G NR module with 2 x external SIM

### GNSS and Onboard Sensor

- 1 x Default U-blox NEO-M8N GNSS module for GPS/Glonass/QZSS/Galileo/Beidou
- Optional M8U modules with dead reckoning available
- G Sensor (3-axis, 10-bit resolution)

### LAN and Power over Ethernet

- 2-Port LAN M12 X-coded, 10/100/1000 Mbps Intel® I210/I219 (support iAMT) GbE
- 8-Port LAN M12 X-coded, 10/100/1000 Mbps Ethernet Switch GbE, PoE 802.3af/at, max. 60W

### Security

- TPM 2.0: Infineon SLB9665TT2.0FW5.62 (BOM optional)

### I/O Interface-Front

- 24 x LED indicators (including 3 x programmable LED)
- 2 x HDMI 1.4b
- 1 x VGA
- 1 x USB 3.1 Gen 2 type A (5V/1A)
- 1 x USB 3.1 Gen 1 type A (5V/1A)
- 6 x Externally accessible SIM card sockets with cover
- 2/4 x 2.5" removable SSD tray
- 1 x SD with cover
- 1 x Reset button
- 1 x Power button
- 10 x SMA antenna

## Dimension Drawing

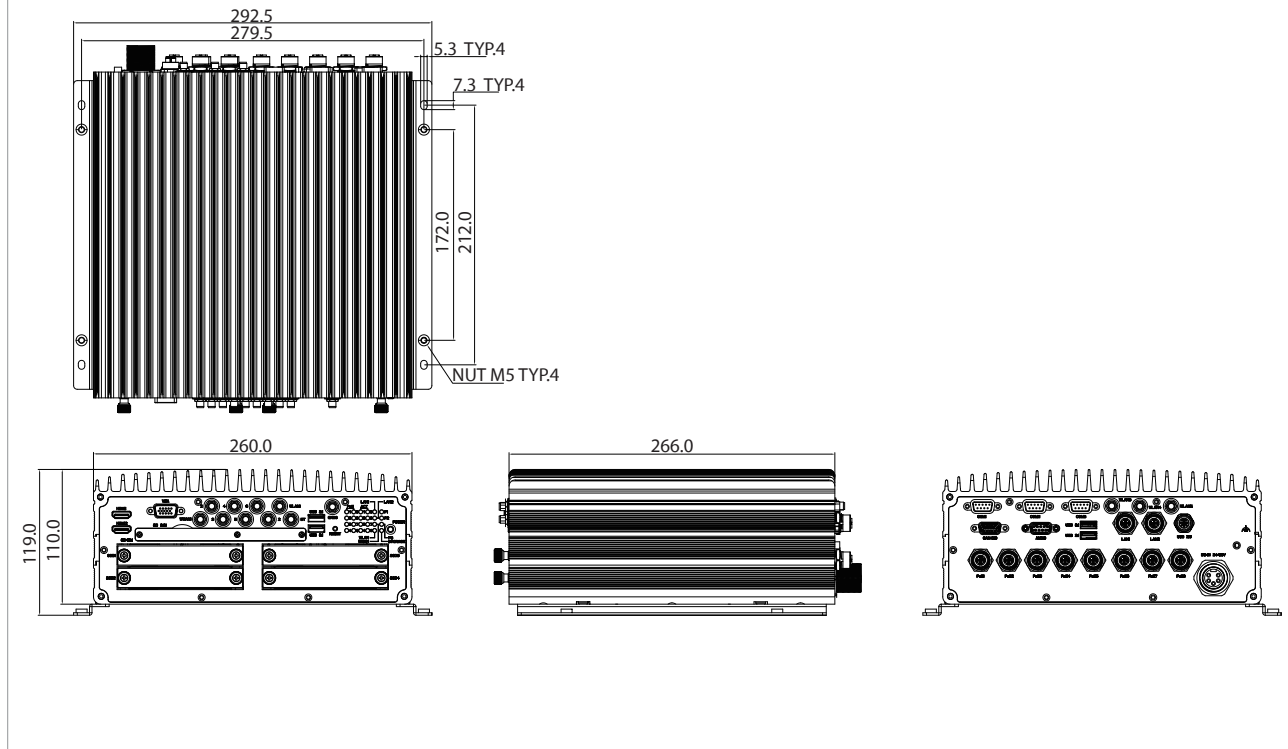

### I/O Interface-Rear

- 2 x LAN M12 X-coded, I210/I219 10/100/1000 Mbps
- 8 x PoE 802.3af/at (max. 60W), M12 X-coded
- 1 x Mic-in, 2 x Line-out (AUDIO, DB9, female)
- 1 x M12 A-coded connector for 2 x USB 2.0
- 2 x USB 3.1 Gen 2 type A (5V/1A)
- 2 x DB9 (COM1/COM2) for full RS232 (isolation)
- 1 x DB9 (COM3) for full RS232/422/485 (isolation)
- 1 x DB15 (CAN/DIO)
  - 1 x Isolated CANBus 2.0B
  - 4 x DI and 4 x DO (isolation)
  - Power in for DIO isolation, 9~48VDC
- 1 x Waterproof DC input connector with ignition
  - DC 24V/36V (w/o isolation), or 24~110VDC (w/ isolation)
- 3 x SMA antenna

### Power Management & Software Support

- nROK 7252-AC8S: power input 24VDC/36VDC w/o isolation
- nROK 7252-WI2-C8S: power input 24~110VDC w/ isolation
- nROK 7252-WI2-C8S: 1.65~3-sec (250W~120W) protection against temporary voltage dips
- Selectable boot-up & shut-down voltage for low power protection by software
- Setting 8-level power on/off delay time by software
- Support S3/S4 suspend mode
- 10~255 seconds WDT support, setup by software
- SDK (Windows/Linux) including utility and sample code

### Operating System

- Windows 10/Linux

### Dimensions

- 260 x 266 x 110 (W x D x H) (mm)

### Weight

- nROK 7252-AC8S: 6.8kg
- nROK 7252-WI2-C8S: 7.6kg

### Environment

- Operating temperatures
  - EN 50155, class OT4 (-40~70°C), 85°C for 10 minutes (w/ 35W TDP CPU, industrial SSD) with air flow

- Storage temperatures: -40°C to 80°C
- Relative humidity: 90% (non-condensing)
- Vibration (random)
  - 2g@5~500 Hz (in operation, SSD)
- Vibration (SSD)
  - Operating: MIL-STD-810G, Method 514.6, Category 4, common carrier US highway truck vibration exposure
  - Storage: MIL-STD-810G, Method 514.6, Category 24, minimum integrity test
- Shock (SSD)
  - Operating: MIL-STD-810G, Method 516.6, Procedure I, functional shock=40g
  - Non-operating: MIL-STD-810G, Method 516.6, Procedure V, crash hazard shock test=75g

### Certifications

- CE
- FCC Class A
- EN 50155: 2017
  - Ambient temperature EN 50155, Class OT4 (-40~70°C), 85°C for 10 minutes
  - Interruptions of voltage supply class S1, S2 (S2 for nROK 7252-WI2-C8S)
  - Supply change over class C1, C2
  - EMC EN 50121-1: 2017, EN 50121-3-2: 2016+A1: 2019
  - Environment EN 60068-2-1, EN 60068-2-2, EN 60068-2-30
  - Shock and vibration IEC 61373 Class B
  - Protective coating class PC1 (PC2, by request)
- EN 45545-2: 2013+A1:2015

## Ordering Information

- **nROK 7252-AC8S (P/N: 10A00725202X0)**  
System bare-bone. Intel® Coffee-Lake S/Refresh/Xeon®, DC input 24V/36V (w/o isolation), 8 x PoE, 4 x SSD tray
- **nROK 7252-WI2-C8S (P/N: 10A00725203X0)**  
System bare-bone. Intel® Coffee-Lake S/Refresh/Xeon®, DC input 24V~110V (w/ isolation), 8 x PoE, 2 x SSD tray