

# NCm-201-2V

2MP Outdoor Vandal Compact Design, Fixed Lens, True WDR, IK10, Image Stabilization, EN-50155, M12 Connector Available



ONVIF

## Main Features

- Full HD1080P @30fps
- Fixed lens 2.8 mm (option 3.6 mm) F1.8
- 100dB True WDR
- IK10 vandal resistance/IP67
- EN50155 certified
- Image stabilization
- Extreme weather -40°C ~ 60°C/-40°F ~ 140°F
- M12 connector as optional



## Product Overview

NEXCOM introduces new mobile dome IP camera offering outstanding 2MP image quality including support for image stabilization function. NCm-201-2V IP Camera, available in indoor and outdoor using scenario, are suitable for transportation surveillance solution, True WDR can overcome variation light condition continued to provide crystal clear image output. IP67 makes IP camera ideal for all kind of extremely working behavior.

### True WDR

The True WDR (Wide Dynamic Range) feature can be very helpful to cope with very challenging lighting conditions. It is capable of capturing both of the dark part and bright part then combining the differences into a scene to generate a highly realistic image. It preserves as much information in the video as possible, the NexCam True WDR IP Camera helps to provide video quality closer to the capabilities of the human eye. Consequently, it is largely applied in high contrast environments such as lobby entrances, parking lots, ATM's and loading areas.

### Extreme Weather

Some NexCam are IP67 and IK10-rated, offering the best protection against extreme weather conditions. By utilizing the latest technologies, operating temperature can range from -40°C to 60°C/-40°F to 140°F.

### Image Stabilization

NexCam offers image stabilization technology, which detects vertical/horizontal movements and utilize sophisticated algorithms to counter the unwanted movements. It is especially practical in transportation applications such as moving vehicles and maritime security.



### Compact Design

NexCam are available in a compact and rugged design to be less intrusive while still offering strong resistance against vandalism and harsh operating environments.

## Specifications

### Camera General Information

Image Sensor	1/3" progressive scan CMOS sensor
Minimum Illumination	B/W 0.05 lux/Color 0.1 lux
Lens	Fixed Lens 2.8 mm F1.8, option 3.6mm F1.8
Iris Type	Fixed Iris
Day and Night	YES
IR Distance	N/A
IR Wavelength	N/A
IR Control	N/A
ICR	N/A
WDR	YES
Image Setting	Brightness, Contrast, Saturation, Sharpness, Backlight compensation, Mirror, Flip, Day/Night, Anti-flicker

### Video

Video Compression	H.264/M-JPEG
Video Streaming	Triple streaming H.264 Stream /H.264 Stream2/MJPEG Stream 3
Video Resolution	1920 x 1080 to 320 x 240
Video Quality	VBR/CBR
Frame Rate	1920 x 1080 @30 fps 1280 x 720 @30 fps 720 x 576 @30 fps 720 x 480 @30 fps 640 x 480 @30 fps 320 x 240 @30 fps

### Audio

Audio Streaming	N/A
Audio Compression	N/A
Audio Input	N/A
Audio Output	N/A

## Dimension Drawing

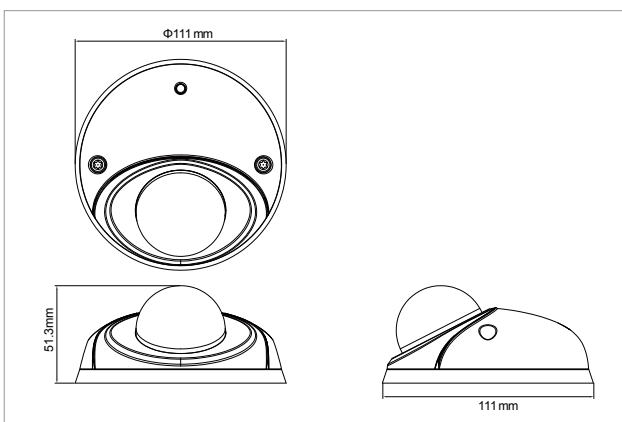

### Network

Interface	10/100/1000 Mbps Ethernet, M12
Supported Protocols	HTTP, TCP/IP, UDP, RTP, RTSP, FTP, SMTP, DHCP, DNS, DDNS, NTP, uPnP, ONVIF, IPv4/v6
Security	Multi-level passwords /HTTPS encryption

### I/O Connector

Audio in/ out Port	N/A
D I/O	N/A
RS485	N/A
Micro SD Card Slot	YES
RJ45	YES

### Event Management

Event trigger	Motion detection, alarm in.
Notifications	Trigger alarm output, email/FTP and record video to FTP server or SD card
Post Recording	YES
Pre Recording	YES

### Power

DC/AC	N/A
POE	IEEE 802.3af

### General

Power Consumption	6W max.
Weight	390g
Dimension	Φ 111mm x 51.3mm (H)
Operating Temp.	-40°C ~ 60°C/-40°F ~ 140°F
Humidity	90% RH (no condensation)
Certification	CE/FCC/EN-50155
Vandal Resistant	IK10
Weather Proof	IP67
Application	SDK available for application development

### Packaging Information

NWT	390g
GWT	650g
Dimension	202 x 166 x 92 (mm)

## Accessories (Optional)



## Ordering Information

- ◆ NCm-201-2V (10H00020101X0)
- ◆ NCm-201-2VM (10H00020103X0) (M12 connector)