



Main Features

- Intel Atom® processor quad core E3950, 1.60 GHz
- Six SIM cards + three WWAN modules support
- Built-in u-blox-M8N GPS
- Built-in CAN Bus 2.0B
- 1 x External storage (compatible with 15mm disk)
- EN 50155, class OT4 conformity
- 3 x mini-PCIe + 2 x M.2 socket expansion
- Wide voltage input 9~48 VDC
- 1 x DB9 for 1 x Mic-in, 2 x Line-out
- Three video outputs, two VGA and one HDMI

Product Overview

nROK 6221, based on Intel® Core™ quad core processor E3950 (1.60 GHz), is specifically comply with stringent EN50155 standard in rugged, fanless and compact mechanism. nROK 6221 provides complete communication capability between train and computer with build-in CAN Bus 2.0B interface. nROK 6221 features rich WLAN and WWAN wireless connectivity. With dual SIM cards per modem support, nROK 6221 allows six SIM cards backup each other for a better connectivity quality or extra bandwidth by software. In addition, six SIM cards and three WWAN modules architecture can increase the bandwidth for a faster data transmission speed. Equipped with intelligent power management, nROK 6221 can be waked on by ignition, RTC timer or SMS message remotely. By integrating the variety of I/O ports, 3 x mini-PCIe, 2 x M.2 sockets expansibility, up to three screens via VGA and HDMI connections, nROK 6221 keeps the flexibility to meet the demand for different rolling stock applications, such as infotainment, dispatching system, cellular/wireless network connectivity, and video surveillance. The design of mini-PCIe slots x 3 can solve the potential request from the market when needed.

Specifications

CPU

- Intel Atom® processor quad core E3950, 1.60 GHz, 12W, 4 core

Memory

- 1 x 204-pin DDR3L SO-DIMM socket support 1866MHz up to 8GB. default 4GB

Video Output

- Chipset Intel® HD graphics 505
- 1 x HDMI 1.4b up to 4096 x 2160 @30Hz
- 2 x VGA up to 1920 x 1200 @60Hz

Storage

- 1 x 2.5" SATA 3.0 external SSD (compatible with 15mm drive)
- 1 x CFast (externally accessible), optional mSATA

Expansion

- 1 x Full size mini-PCIe socket (USB 2.0) for LTE module with 2 x external SIM
- 1 x Full size mini-PCIe socket (USB 2.0, PCIe 2.0), BOM optional full size mini-PCIe socket (USB 2.0) for LTE module with 2 x external SIM
- 1 x Full size mini-PCIe socket (USB 2.0, PCIe 2.0)
- 1 x M.2 3042 Key B socket (USB 2.0, USB 3.0) for LTE/5G NR module with 2 x external SIM

- 1 x M.2 3042/3050/3052 Key B socket (USB 2.0, USB 3.0, PCIe 2.0 (BOM optional)) for LTE/5G NR module with 2 x external SIM

GNSS and Onboard Sensor

- 1 x Default u-blox NEO-M8N GNSS for GPS/Glonass/QZSS/Galileo/Beidou
- G Sensor (3-axis, 10-bit resolution)

LAN

2-Port LAN, 10/100/1000 Mbps Intel® I210-IT GbE, BOM optional 3-port LAN

Security

- TPM 2.0: Infineon SLB9665TT2.0FW5.62 (BOM optional)

I/O Interface-Front

- 12 x LED indicators (including 2 x programmable LED)
- 6 x Externally accessible SIM card sockets with cover
- 1 x 2.5" removable SSD tray
- 1 x Externally accessible CFast card socket with cover
- 1 x Reset button
- 1 x Power button
- 1 x USB 3.0 type A (5V/0.9A)
- 14 x SMA antenna

Dimension Drawing

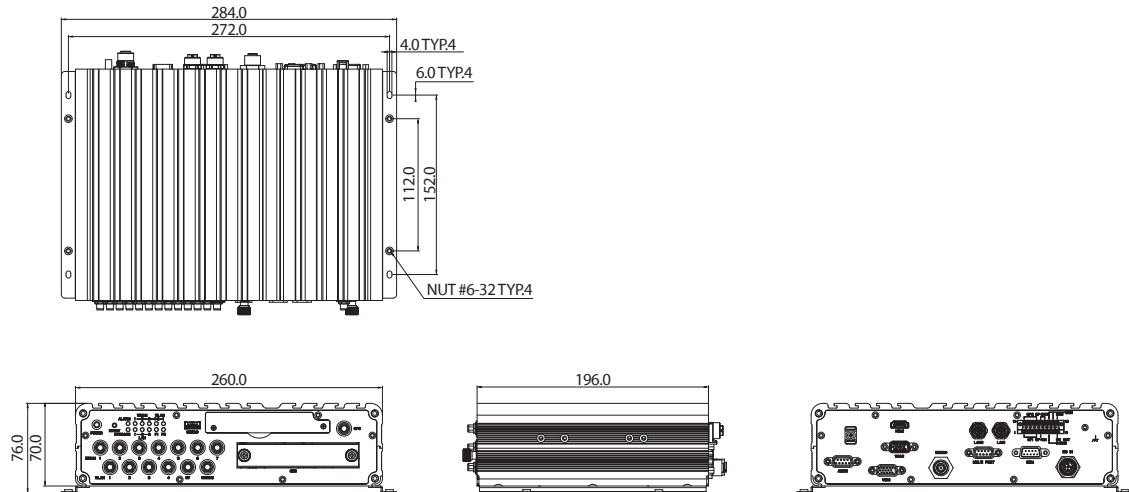

I/O Interface-Rear

- 1 x Circle type DC input with ignition
 - 24/36 VDC (9~48 VDC), non-isolation
- 1 x M12 with two USB 2.0
- 2 x M12 X-coded LAN port, 10/100/1000 Mbps
- 1 x DB9 (AUDIO), female for 1 x Mic-in, 2 x Line-out
- 2 x VGA
- 1 x HDMI 1.4b
- 1 x DB9 (COM) full RS232 (isolation)
- 1 x DB9 (MULTI PORT) for RS232 TX/RX, RS485 (all w/ isolation), USB 2.0
- 1 x 18-pin terminal block
 - 1 x CAN Bus 2.0B (onboard)
 - 4 x DI with isolation
 - 4 x DO with isolation
 - Vin, GND for GPIO

Power Management & Software Support

- Power input 24/36 VDC w/o isolation
- Selectable boot-up & shut-down voltage for low power protection by software
- Setting 8-level power on/off delay time by software
- Support S3/S4 suspend mode
- 10~255 seconds WDT support, setup by software
- SDK (Windows/Linux) including utility and sample code

Operating System

- Windows 10/Linux

Dimensions

- 260mm (W) x 196mm (D) x 70mm (H) (10.24" x 7.79" x 2.75")

Weight

- 2.8kg

Environment

- Operating temperatures
 - EN 50155, class OT4 (-40~70°C), 85°C for 10 minutes (w/ industrial SSD) with air flow

- Storage temperatures: -40°C to 80°C
- Relative humidity: 10% to 90% (non-condensing)
- Vibration (random)
 - 2g@5~500 Hz (in operation, SSD)
- Vibration (SSD)
 - Operating: MIL-STD-810G, Method 514.6, Category 4, common carrier US highway truck vibration exposure
 - Storage: MIL-STD-810G, Method 514.6, Category 24, minimum integrity test
- Shock (SSD)
 - Operating: MIL-STD-810G, Method 516.6, Procedure I, functional shock=40g
 - Non-operating: MIL-STD-810G, Method 516.6, Procedure V, crash hazard shock test=75g

Standards/Certifications

- CE
- FCC Class A
- EN 50155: 2017
 - Ambient temperature EN 50155, Class OT4 (-40~70°C), 85°C for 10 minutes
 - Interruptions of voltage supply class S1
 - Supply change over class C1, C2
- EMC EN 50121-3-2: 2016
- Environment EN 60068-2-1, EN 60068-2-2, EN 60068-2-30
- Shock and vibration IEC 61373 Class B
- Protective coating class PC1 (PC2, by request)
- EN 45545-2:2013+A1:2015 (PCB)

Ordering Information

• nROK 6221-A (P/N: 10A00622100X0)

Intel Atom® processor E3950 1.60 GHz CPU, 4GB DDR3L SO-DIMM, DC input 24/36 VDC w/o isolation, 2 x VGA, 1 x HDMI, 2 x LAN, 2 x RS232, 1 x RS485, 4 x DI, 4 x DO, 4 x USB